



CATALOGUE 2025

50hz | English





The best materials for your pump

Long service life thanks to research to improve the quality of materials and manufacturing processes.



From raw material to finished product

Our integrated production chain ensures efficient control of the production process, from sourcing to final distribution.



Sustainability and durability

Our pumps are strong and reliable, not only because of the durability of the materials and the solidity of their manufacture, but also because of the availability of spare parts and the network of technical services.



All our pumps are recyclable

95% of the components in our product range are recyclable.



Born in
1962



+60 years of
growth in the
industry



Design,
production and
distribution

95%

Made in
Europe



Reach up
to **+100**
countries



Essence, soul
and **identity**



10
subsidiaries
join us



Our applications

Groundwater

Long-term solutions

Extraction of water from wells, tanks or natural sources, using pumps which ensure a constant, reliable flow, facilitating the initial supply for domestic, residential or agricultural facilities.



Supply

Water when and where you need it

Transportation and distribution of water from source to the point of use, ensuring a stable, sufficient flow pressure in homes, communities or industries, deploying equipment designed for speedy installation and reduced maintenance.



Recirculation and filtration

The perfect duo to ensure ever clean water

Systems that keep water in continuous movement and free of impurities, accompanied by filtering processes to maintain its quality and cleanliness and optimal usage conditions. Essential for swimming pools, spas or closed circuits such as heating, with compact and easy-to-install solutions.



Evacuation

Say goodbye to water, say hello to efficiency

Controlled drainage and disposal of residual, storm or surplus water, using equipment that guarantees safe and efficient evacuation in domestic, commercial or industrial applications.





With more than 60 years of experience, we have promoted with dedication the path towards more conscious and efficient water management, promoting responsible consumption and the ingenious use of this vital resource.

GROUNDWATER

> Submersibles

10	Acuaria 07S
11	Acuaria 17
12	Acuaria 27
13	Acuaria 37
14	Acuaria 57
15	Vigilarain

> Submersible wet ends and motors

16	ES4
21	Motor O4IB

SUPPLY

> Horizontal surface

24	Delta
25	Prisma 15
26	Prisma 25
27	Prisma 35N
28	Prisma 45N
29	Aspri 15
30	Aspri 20
31	Aspri 25
32	Aspri 35N
33	Aspri 45N
34	Tecno 05
35	Tecno 15
36	Tecno 25

> Vertical surface

37	Multi 25
38	Multi 35N
39	Multi 55N
40	VE 94
41	VE 121N
42	Multi VS 05
43	Multi VS 10
44	Multi VS 15
45	Multi VS 20

> Automation devices

47	Pressdrive
48	Pressdrive 05
49	Speedrive V2

> Booster

50	PDS
51	PDS 05
52	Tecnopres
53	Acuapres S
54	Tecnoplus 15
55	Tecnoplus 25
56	CPE
57	CKE 1
58	CKE 2 Prisma
59	CKE 2
62	CKE 3
65	CKE 4
68	Booster sets
69	Fire-fighting sets

RECIRCULATION AND FILTRATION

> Recirculation

72	Nox 20
73	Nox 25
74	Nox 33/50/100
75	Nox 75/100/150
76	Silen I
77	Silen S
78	Silen S2
79	Noxsalt
80	Noxsalt plus
81	Noxplus
82	Noxplus 2
83	Silenplus 1
84	Silenplus 2
85	Silenplus 3

> Filtration

86	Neat
87	Filterkit Base
88	Filterkit Plus

> Cleaning

89	Multipool N
----	-------------

> Counter-current

90	Nadorsel
----	----------

> Whirlpool and spa

91	Tiper
92	Wiper
93	Wiper 3

> Other applications

94	Piscis
----	--------

EVACUATION

> Drainage

98	Vigila
99	Vigilex
100	Vigicor
101	Drain 100
102	Drainex 100
103	Drainex 200
105	Drainex 300
107	Drainex 400
109	Drainex 500
111	Drainex 600
113	Draincor
115	Drainbox

ACCESSORIES

118	Accessories
-----	-------------

INFORMATION

120	Regulations
-----	-------------





Groundwater

Long-term
solutions



Acuaría 07S Groundwater | Submersibles



Submersible monoblock centrifugal multistage pump for water supply

Applications

Pumping of clean water for domestic, industrial, agricultural and gardening purposes. Suitable for open wells, ponds and tanks.

Materials

Pump body, suction, discharge, filter and impellers in AISI 304. Pump shaft in AISI 431. Diffusers in technopolymer. Double mechanical seal. O-rings in NBR/EPDM.

Equipment

Check valve not included. Model MA with float switch. Model M/T without float switch. Cable, plug and capacitor: see table.

Motor

Asynchronous 2 poles. IPX8 protection. Class F insulation. Continuous operation. Water cooled motor. Single phase motor with built-in thermal protection.

Range of use

Maximum water temperature 40 °C. Maximum submersion 12m.



Model MA

Model M/T



Stainless steel impellers



External capacitor (optional)



Quiet



Pressure up to 70 m



Flow rate up to 65 l/min

Features table

Model	I [A]		P1 [kW]		P2		c [µF]	l/min	10	20	30	40	50	60	65
	1~230V	3~400V	1~	3~	[kW]	[HP]			m ³ /h	0,6	1,2	1,8	2,4	3,0	3,6
Acuaría 07S 3	2,9	-	0,65	-	0,5	0,65	12	mwc	33	29	26	21	15	8	4
Acuaría 07S 4	4	1,5	0,9	0,8	0,55	0,75	12		41	37	32	26	19	10	6
Acuaría 07S 5	4,7	2,2	1	1	0,75	1	12		50	46	40	32	23	13	8
Acuaría 07S 6	6,2	2,2	1,2	1,1	0,9	1,2	12		60	55	47	37	26	15	9
Acuaría 07S 7	6,5	2,4	1,25	1,3	1,1	1,5	12		70	64	55	44	31	18	11

Model	Code with internal capacitor and 15m of cable with plug type F.		Code CCE with external capacitor with capacitor box and 15m of cable with plug type F.		Code CEXT with external capacitor without capacitor box and 15m of cable without plug.		Code
	1~230V (Model M cable without plug)	1~230V (Model MA)	1~230V (Model M CCE)	1~230V (Model MA CCE)	1~230V (Model M CEXT)	1~230V (Model MA CEXT)	
Acuaría 07S 3	209123	209078	209401	209353	209133	209127	-
Acuaría 07S 4	209122	209079	209387	209135	209130	209126	209194
Acuaría 07S 5	209124	209080	209402	209136	209131	209128	209196
Acuaría 07S 6	209125	209081	209403	209358	209132	209129	209340
Acuaría 07S 7	-	-	209404	209137	209134	209082	209344

Performance curve at 2900 rpm

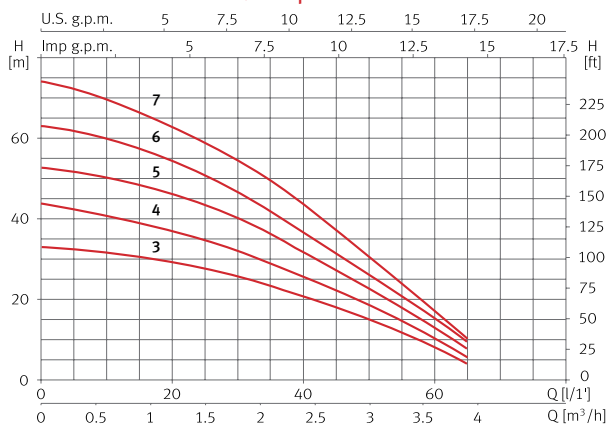

Dimension and weight

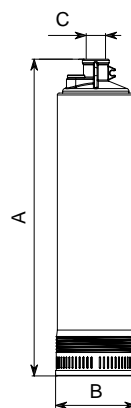

Model	A	B	C	Kg
Acuaría 07S 3	479	125	1"	10
Acuaría 07S 4	502	125	1"	10,6
Acuaría 07S 5	526	125	1"	11,5
Acuaría 07S 6	569	125	1"	12,4
Acuaría 07S 7	593	125	1"	12,6

Accessories	Code
5" top suction float kit	177113



Submersible monoblock centrifugal multistage pump for water supply

Applications

Pumping of clean water for domestic, industrial, agricultural and gardening purposes.
Suitable for open wells, ponds and tanks.

Materials

Pump body, suction, discharge, filter and impellers in AISI 304.
Pump shaft in AISI 431.
Diffusers in technopolymer.
Double mechanical seal.
O-rings in NBR/EPDM.

Equipment

Check valve not included.
Model MA with float switch.
Model M/T without float switch.
15m of cable without plug.
External capacitor.

Motor

Asynchronous 2 poles.
IPX8 protection.
Class F insulation.
Continuous operation.
Water cooled motor.
Single phase motor with built-in thermal protection.

Range of use

Maximum water temperature 40 °C.
Maximum submersion 12m.



Model MA

Model M/T



Stainless steel impellers



External capacitor



Quiet



Pressure up to 95 m



Flow rate up to 85 l/min

Features table

Model	I [A]		P1 [kW]		P2		c [μF]	l/min									Code		
	1~230V	3~400V	1~	3~	[kW]	[HP]			10	20	30	40	50	60	80	85	1~230V (Model M)	1~230V (Model MA)	3~400V (Model T)
Acuaría 17 5	7,4	2,6	1,6	1,5	0,9	1,2	16	mwc	0,6	1,2	1,8	2,4	3,0	3,6	4,8	5,1	96265	96266	96251
Acuaría 17 7	10,7	3,8	2,2	2,1	1,5	2	25		94	90	85	78	69	58	30	22	96282	96283	96275

Performance curve at 2900 rpm

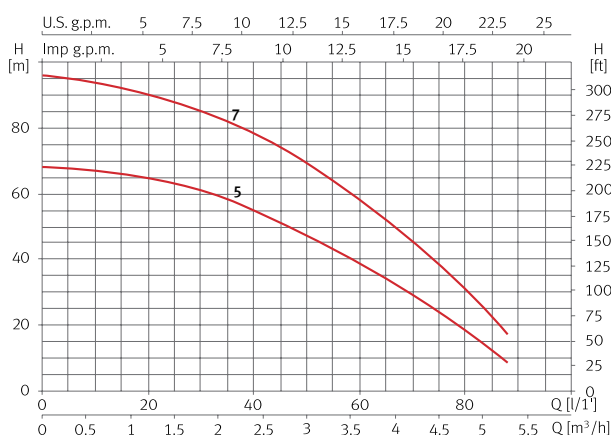

Dimension and weight

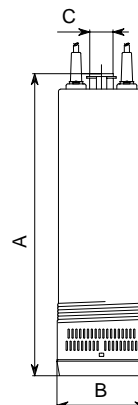

Model	A	B	C	Kg
Acuaría 17 5	554	138	1"	19,8
Acuaría 17 7	646	138	1"	24

Submersible monoblock centrifugal multistage pump for water supply

Applications

Pumping of clean water for domestic, industrial, agricultural and gardening purposes.
Suitable for open wells, ponds and tanks.

Materials

Pump body, suction, discharge, filter and impellers in AISI 304.
Pump shaft in AISI 431.
Diffusers in technopolymer.
Double mechanical seal.
O-rings in NBR/EPDM.

Equipment

Check valve not included.
Model MA with float switch.
Model M/T without float switch.
15m of cable without plug.
External capacitor.

Motor

Asynchronous 2 poles.
IPX8 protection.
Class F insulation.
Continuous operation.
Water cooled motor.
Single phase motor with built-in thermal protection.

Range of use

Maximum water temperature 40 °C.
Maximum submersion 12m.



Model MA

Model M/T



Stainless steel impellers



External capacitor



Quiet



Pressure up to 70 m



Flow rate up to 120 l/min

Features table

Model	I [A]		P1 [kW]		P2		c [μF]	l/min	20	30	40	50	60	80	100	120	Code		
	1~230V	3~400V	1~	3~	[kW]	[HP]											1~230V (Model M)	1~230V (Model MA)	3~400V (Model T)
Acuaria 27 4	7	2,5	1,5	1,4	1,25/0,9	1,2	16	m³/h	1,2	1,8	2,4	3,0	3,6	4,8	6,0	7,2	96342	96343	96328
Acuaria 27 6	10,8	3,8	2,2	2,1	2/1,5	2	25	m³/h	68	66	64	61	57	47	36	24	96359	96360	96352

Performance curve at 2900 rpm

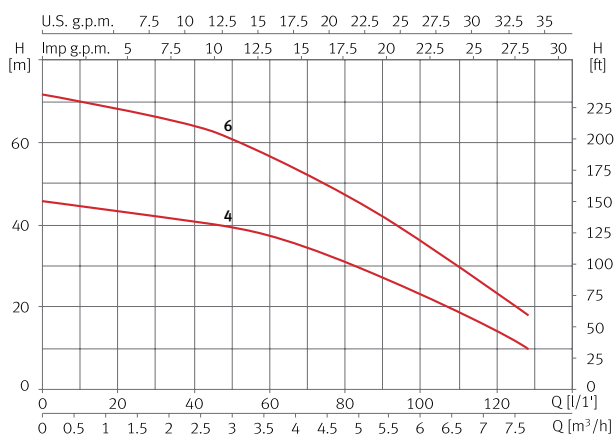

Dimension and weight

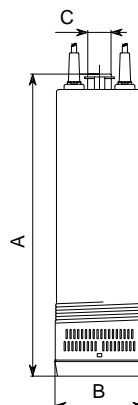

Model	A	B	C	Kg
Acuaria 27 4	552	138	1"	20
Acuaria 27 6	665	138	1"	24

Submersible monoblock centrifugal multistage pump for water supply

Applications

Pumping of clean water for domestic, industrial, agricultural and gardening purposes.
Suitable for open wells, ponds and tanks.

Materials

Pump body, filter and impellers in AISI 304.
Suction and discharge in cast iron.
Pump shaft in AISI 431.
Diffusers in technopolymer.
Double mechanical seal.
O-rings in NBR/EPDM.

Equipment

Check valve not included.
15m of cable without plug.
External capacitor.

Motor

Asynchronous 2 poles.
IPX8 protection.
Class F insulation.
Continuous operation.
Water cooled motor.
Single phase motor with built-in thermal protection.

Range of use

Maximum water temperature 40 °C.
Maximum submersion 12m.



Stainless steel impellers	External capacitor	Quiet	Pressure up to 85 m	Flow rate up to 175 l/min

Features table

Model	I [A]		P1 [kW]		P2		c [μF]	l/min	12	40	60	100	120	140	160	Code	
	1~230V	3~400V	1~	3~	[kW]	[HP]			m³/h	1,2	2,4	3,6	6,0	7,2	8,4	8,6	1~230V
Acuaría 37 4	9,2	3,3	2	1,9	1,1	1,5	30	mwc	56	53	51	41	35	29	22	135380	135379
Acuaría 37 6	-	5,3	-	3	2,2	3	-		85	81	77	65	56	46	37	-	135381

Performance curve at 2900 rpm

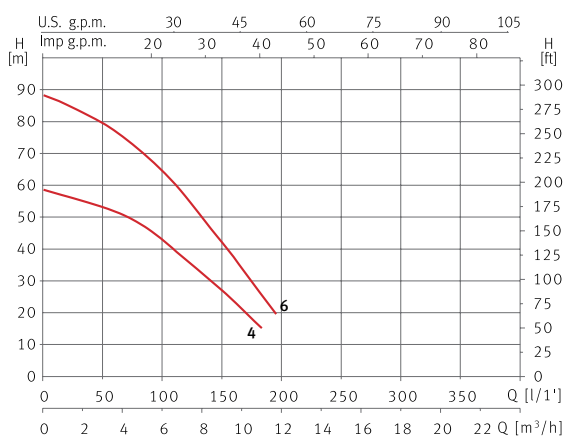

Dimension and weight

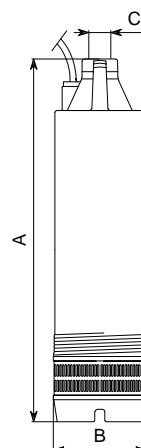

Model	A	B	C	Kg
Acuaría 37 4	623	152	1 1/2"	27,6
Acuaría 37 6	672	152	1 1/2"	30,6

Submersible monoblock centrifugal multistage pump for water supply

Applications

Pumping of clean water for domestic, industrial, agricultural and gardening purposes.
Suitable for open wells, ponds and tanks.

Materials

Pump body, filter and impellers in AISI 304.
Suction and discharge in cast iron.
Pump shaft in AISI 431.
Diffusers in technopolymer.
Double mechanical seal.
O-rings in NBR/EPDM.

Equipment

Check valve not included.
15m of cable without plug.

Motor

Asynchronous 2 poles.
IPX8 protection.
Class F insulation.
Continuous operation.
Water cooled motor.

Range of use

Maximum water temperature 40 °C.
Maximum submersion 12m.



Stainless steel impellers



Quiet



Pressure up to 55 m



Flow rate up to 350 l/min

Features table

Model	I [A]	P1 [kW]	P2		l/min	50	100	150	200	250	300	350	Code
	3~400V	3~	[kW]	[HP]	m³/h	3,0	6,0	9,0	12	15	18	21	3~400V
Acuaría 57 4	5,4	3	2,2	3	mwc	53	48	42	38	32	23	12	135382

Performance curve at 2900 rpm

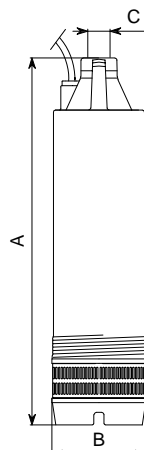
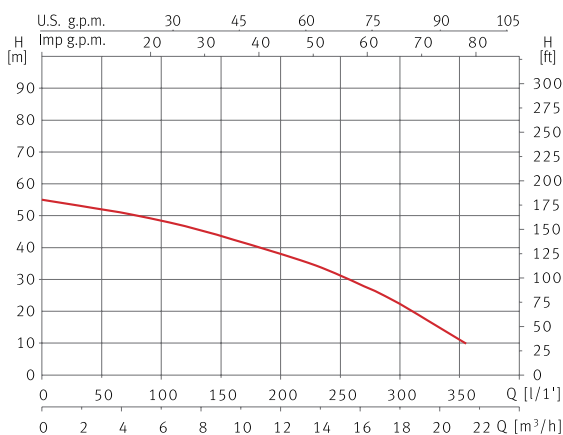

Dimension and weight

Model	A	B	C	Kg
Acuaría 57 4	684	152	1 1/2"	30,6

Submersible monoblock centrifugal multistage pump for water supply

Applications

Pumping of recovered rainwater for domestic and gardening use.
Suitable for tanks and cisterns.

Materials

Pump body in AISI 304.
Pump shaft in AISI 420.
Suction in technopolymer.
Impeller in technopolymer reinforced with steel.
Mechanical seal.
O-rings in NBR/EPDM.

Equipment

Float switch and 10m of cable with plug type F.
Internal capacitor.

Motor

Asynchronous 2 poles.
IPX8 protection.
Continuous operation.
Class F insulation.
Built-in thermal protection.

Range of use

Maximum water temperature 40 °C.
Maximum submersion 7m.

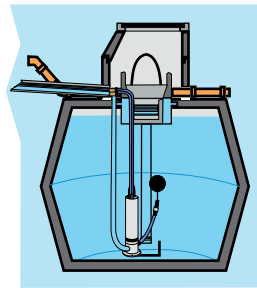

Flow rate up to 250 l/min



Rainwater harvesting

Features table

Model	I [A]	P1 [kW]	P2		c [μF]	l/min	25	50	100	150	200	250	Code
	1~230V	1~	[kW]	[HP]									
Vigilarain	5	1,1	0,9	1,2	16	mwc	13	12,5	11,5	9,5	7	3	97820

Performance curve at 2900 rpm

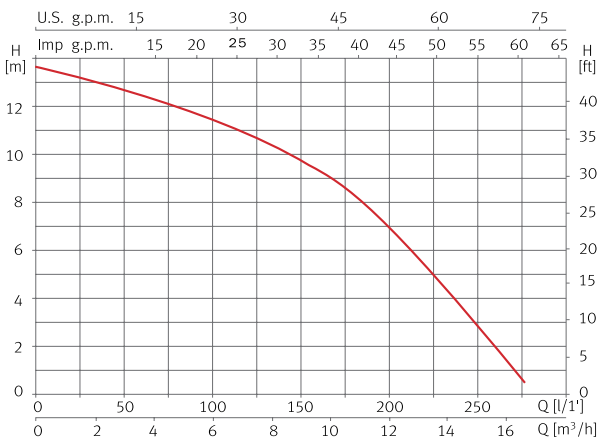

Dimension and weight

Model	A	B	C	D	Kg
Vigilarain	511	464	194	1 1/4"	14,8

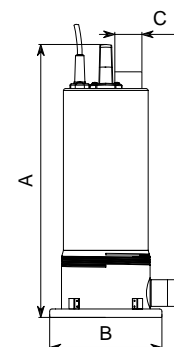

Submersible 4" wet end

Applications

Assembled on a motor, pumping of clean water for domestic, industrial, agricultural and gardening purposes. Suitable for boreholes.

Materials

Pump body, suction, discharge and pump shaft in AISI 304.
Diffusers and floating impellers in technopolymer.
O-rings in NBR/EPDM.

Equipment

Built-in check valve.
Joint kit according to regulation NEMA MG1-18.388.

Range of use

Maximum water temperature 40 °C.
Maximum quantity of sand in suspension 100 g/m³.



Features table, performance curve at 2900 rpm, dimension and weight

Model	P2		l/min m ³ /h	0	5	10	15	20	25	Code
	[kW]	[HP]		0	0,3	0,6	0,9	1,2	1,5	
ES4 01 19	0,55	0,75	mwc	126	118	105	86	60	30	157698
ES4 01 26	0,75	1		173	160	141	117	81	39	157699
ES4 01 38	1,1	1,5		253	234	208	169	117	52	157700

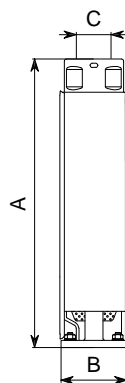
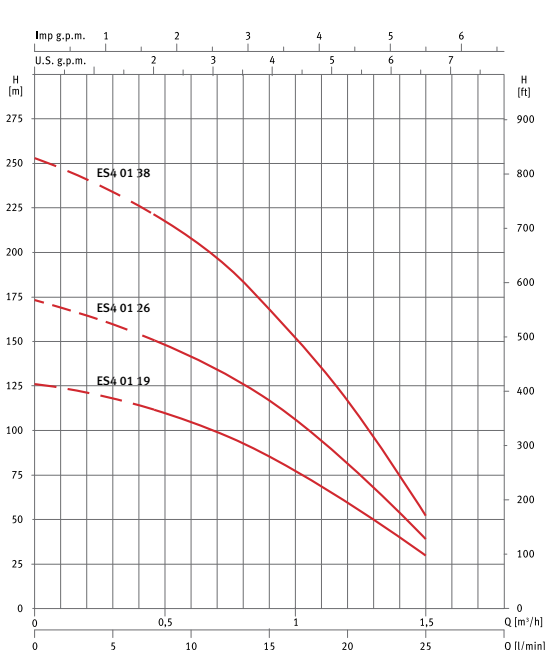

Model	A	B	C	Kg
ES4 01 19	481	98	1 1/4"	4,7
ES4 01 26	642	98	1 1/4"	5,8
ES4 01 38	864	98	1 1/4"	8,2

Features table, performance curve at 2900 rpm, dimension and weight

Model	P2		l/min m³/h	0	20	25	30	40	50	Code
	[kW]	[HP]		0	1,2	1,5	1,8	2,4	3,0	
ES4 02 10	0,55	0,75	mwc	69	63	60	55	44	29	157703
ES4 02 14	0,75	1		92	83	79	74	60	42	157704
ES4 02 20	1,1	1,5		139	127	120	111	90	60	157705
ES4 02 28	1,5	2		193	176	167	155	125	83	162589

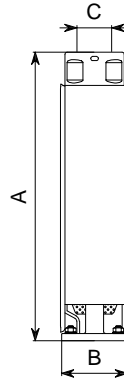
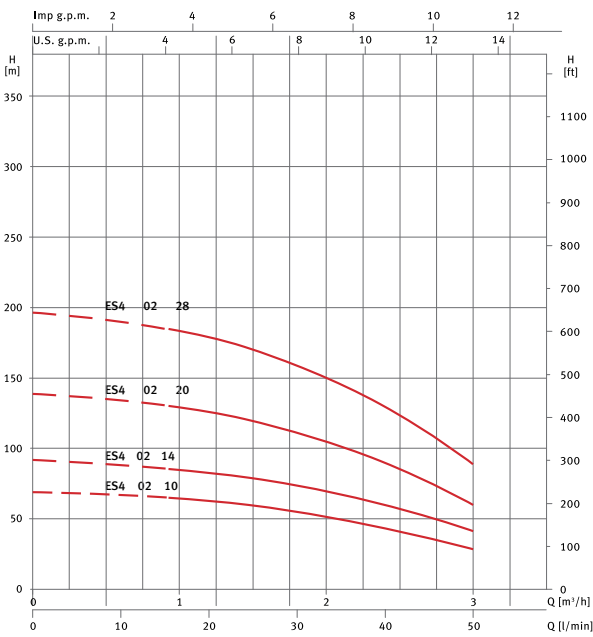

Model	A	B	C	Kg
ES4 02 10	324	98	1 1/4"	3,3
ES4 02 14	394	98	1 1/4"	3,9
ES4 02 20	499	98	1 1/4"	4,9
ES4 02 28	640	1090	1 1/4"	6,2

Features table, performance curve at 2900 rpm, dimension and weight

Model	P2		l/min m³/h	0	20	30	40	50	70	Code
	[kW]	[HP]		0	1,2	1,8	2,4	3,0	4,2	
ES4 03 11	0,75	1	mwc	72	68	64	58	49	26	157708
ES4 03 16	1,1	1,5		106	101	95	83	70	33	157709
ES4 03 21	1,5	2		142	135	127	115	100	49	157710
ES4 03 32	2,2	3		208	200	187	165	138	62	157711

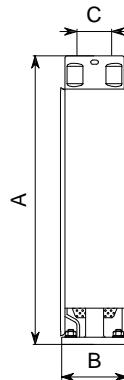
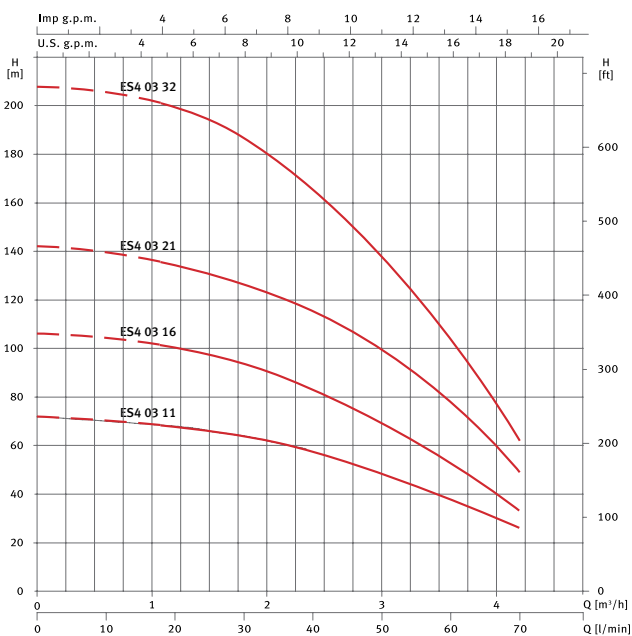

Model	A	B	C	Kg
ES4 03 11	342	98	1 1/4"	3,4
ES4 03 16	430	98	1 1/4"	4,2
ES4 03 21	519	98	1 1/4"	5,0
ES4 03 32	749	98	1 1/4"	7,1

Features table, performance curve at 2900 rpm, dimension and weight

Model	P2		l/min m ³ /h	0	40	50	70	90	100	Code
	[kW]	[HP]		0	2,4	3,0	4,2	5,4	6,0	
ES4 04 08	0,75	1	mwc	51	46	43	35	24	18	157714
ES4 04 12	1,1	1,5		77	71	68	57	41	31	157715
ES4 04 16	1,5	2		102	96	92	77	57	46	157716
ES4 04 24	2,2	3		151	139	132	111	80	62	157717
ES4 04 32	3	4		203	185	175	146	105	80	157718
ES4 04 44	4	5,5		278	260	247	210	159	127	157720

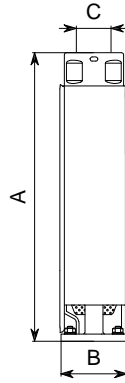
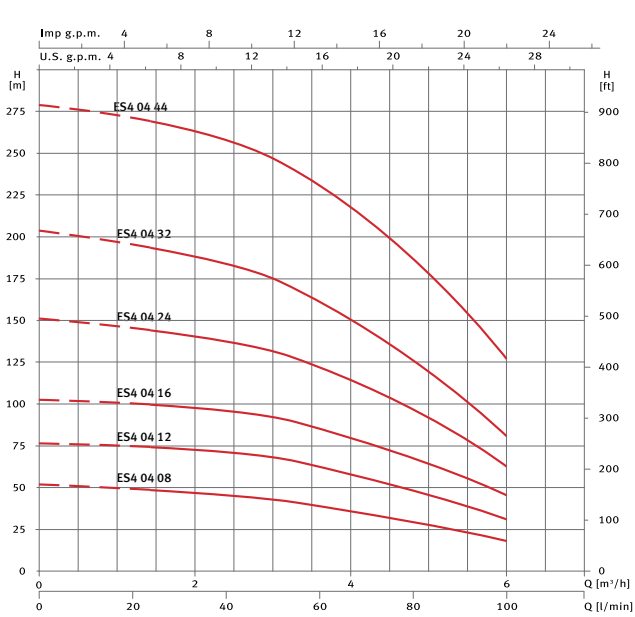

Model	A	B	C	Kg
ES4 04 08	345	98	1 1/4"	3,3
ES4 04 12	433	98	1 1/4"	4,1
ES4 04 16	542	98	1 1/4"	5,0
ES4 04 24	777	98	1 1/4"	6,6
ES4 04 32	965	98	1 1/4"	8,7
ES4 04 44	1296	98	1 1/4"	11,2

Features table, performance curve at 2900 rpm, dimension and weight

Model	P2		l/min m ³ /h	0	50	70	90	120	140	Code
	[kW]	[HP]		0	3,0	4,2	5,4	7,2	8,4	
ES4 06 07	0,75	1	mwc	42	36	32	28	19	11	157721
ES4 06 10	1,1	1,5		62	53	48	41	29	18	157722
ES4 06 14	1,5	2		90	77	71	63	46	28	157723
ES4 06 20	2,2	3		125	107	97	86	62	40	157724
ES4 06 27	3	4		169	145	131	115	84	55	157725
ES4 06 36	4	5,5		221	190	173	154	112	72	157727

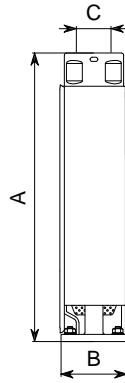
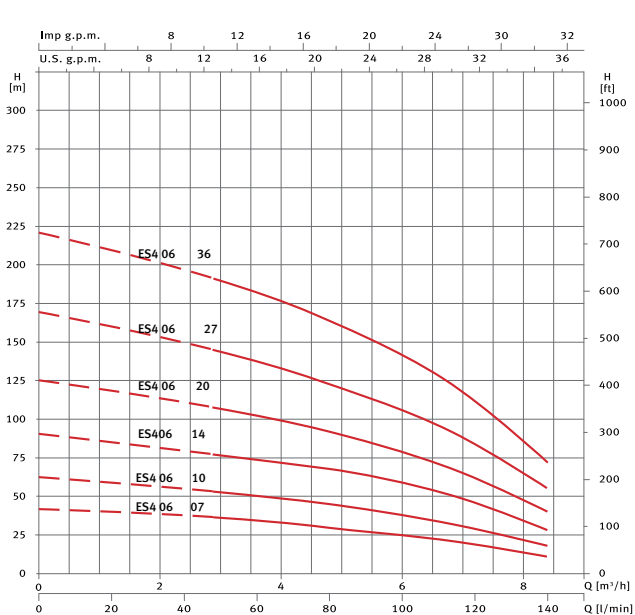

Model	A	B	C	Kg
ES4 06 07	390	98	2"	3,7
ES4 06 10	483	98	2"	4,6
ES4 06 14	607	98	2"	5,7
ES4 06 20	831	98	2"	7,5
ES4 06 27	1048	98	2"	9,6
ES4 06 36	1318	98	2"	12,2

Features table, performance curve at 2900 rpm, dimension and weight

Model	P2		l/min m ³ /h	0	80	100	140	180	200	Code
	[kW]	[HP]		0	4,8	6,0	8,4	10,8	12	
ES4 08 06	1,1	1,5	mwc	39	36	34	29	22	17	157730
ES4 08 08	1,5	2		52	48	46	39	29	24	157731
ES4 08 13	2,2	3		82	75	71	59	40	30	157732
ES4 08 17	3	4		108	98	94	79	58	46	157733
ES4 08 23	4	5,5		148	134	127	108	79	60	157735
ES4 08 32	5,5	7,5		202	182	172	143	105	80	157736

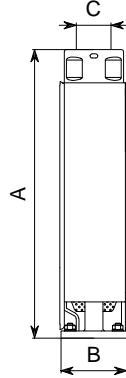
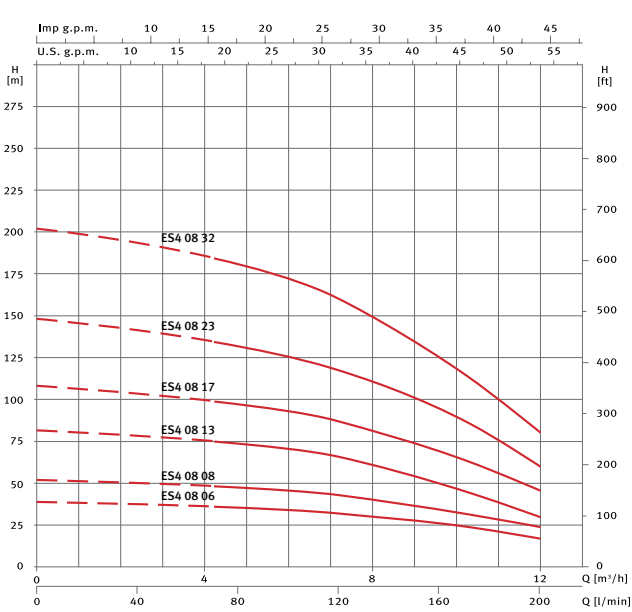

Model	A	B	C	Kg
ES4 08 06	356	98	2"	3,4
ES4 08 08	418	98	2"	4,0
ES4 08 13	573	98	2"	5,5
ES4 08 17	697	98	2"	6,6
ES4 08 23	921	98	2"	8,4
ES4 08 32	1238	98	2"	11,0

Features table, performance curve at 2900 rpm, dimension and weight

Model	P2		l/min m ³ /h	0	100	140	180	220	260	Code
	[kW]	[HP]		0	6,0	8,4	10,8	13,2	15,6	
ES4 12 07	1,5	2	mwc	45	37	33	28	22	14	157737
ES4 12 10	2,2	3		64	54	48	41	32	20	157738
ES4 12 14	3	4		89	76	67	56	43	28	157739
ES4 12 19	4	5,5		120	102	91	76	58	37	157741
ES4 12 26	5,5	7,5		163	136	120	100	75	48	157742

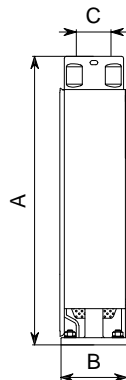
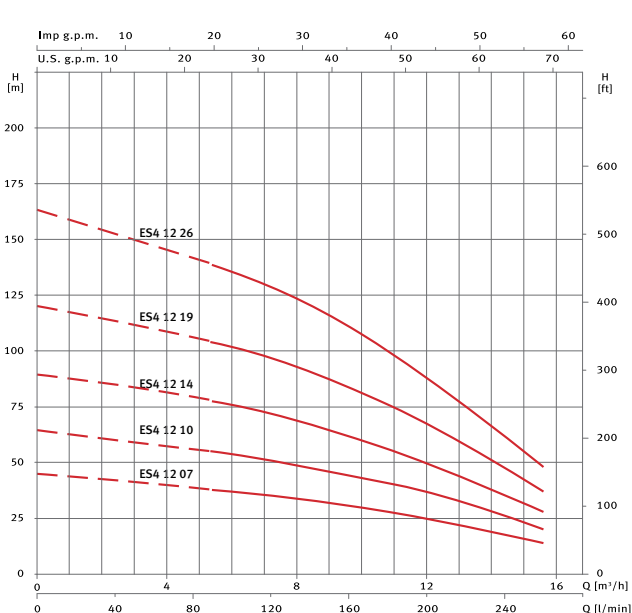

Model	A	B	C	Kg
ES4 12 07	534	98	2"	5,3
ES4 12 10	690	98	2"	6,7
ES4 12 14	989	98	2"	8,6
ES4 12 19	1195	98	2"	11,0
ES4 12 26	1559	98	2"	14,3

Features table, performance curve at 2900 rpm, dimension and weight

Model	P2		l/min m ³ /h	0	140	200	260	320	400	Code
	[kW]	[HP]		0	8,4	12	15,6	19,2	24	
ES4 16 08	2,2	3	mwc	51	41	35	29	22	12	157743
ES4 16 11	3	4		70	57	49	41	31	18	157744
ES4 16 13	4	5,5		81	67	58	48	38	22	157745
ES4 16 15	4	5,5		97	79	69	58	46	27	157746
ES4 16 20	5,5	7,5		125	102	89	74	60	37	157747

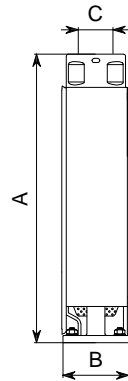
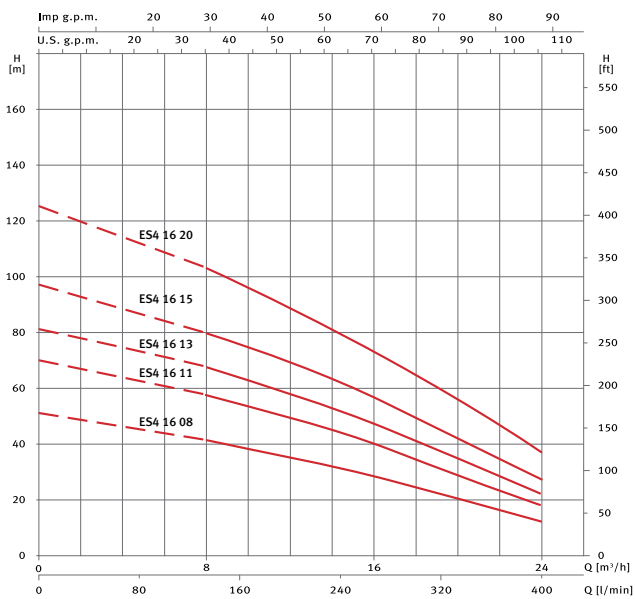

Model	A	B	C	Kg
ES4 16 08	676	98	2"	6,3
ES4 16 11	880	98	2"	8,1
ES4 16 13	1013	98	2"	9,3
ES4 16 15	1149	98	2"	10,5
ES4 16 20	1489	98	2"	13,5

Submersible motor for 4" wet end

Applications

To be assembled on 4" submersible wet end.

Materials

Motor casing and shaft in AISI 304.
O-rings in NBR/EPDM.

Equipment

Cable without plug (see table).
Joint kit according regulation
NEMA MG1-18.388.
External capacitor.

Motor

Asynchronous 2 poles.
IPX8 protection.
Class F insulation.
Continuous operation.
Oil cooled motor.
Single phase motor with built-in thermal protection.

Range of use

Maximum water temperature 35 °C.



Features table

Model	I [A]	P1 [kW]	P2		c [μF]	Cos φ	η %	I _{arr} [A]	Axial [N]	Cable		Code
	1~ 230V	1~	[kW]	[HP]						Ø [mm ²]	L [m]	1~230V
O4I 075M	4,7	0,97	0,55	0,75	25	0,88	56	16,5	2000	4 x 1,5	1,7	189188
O4I 100M	5,9	1,2	0,75	1	35	0,90	62	18,9	2000	4 x 1,5	1,7	189189
O4I 150M	8,3	1,7	1,1	1,5	40	0,91	65	26,2	2000	4 x 1,5	1,7	189190
O4I 200M	10,7	2,3	1,5	2	60	0,93	66	35	2000	4 x 1,5	1,7	189192
O4I 300M	15,2	3,3	2,2	3	80	0,93	67	47	3000	4 x 1,5	1,7	189191

Model	I [A]		P1 [kW]	P2		Cos φ		η %		I _{arr} [A]		Axial [N]	Cable		Code	
	3~ 230V	3~ 400V	3~	[kW]	[HP]	3~ 230V	3~ 400V	3~ 230V	3~ 400V	3~ 230V	3~ 400V		Ø [mm ²]	L [m]	3~230V	3~400V
O4I 075	-	2	0,95	0,55	0,75	-	0,65	-	58	-	8	2000	4 x 1,5	1,7	-	189205
O4I 100	4,5	2,5	1,2	0,75	1	0,68	0,77	62	61	17,1	9,4	2000	4 x 1,5	1,7	189195	189206
O4I 150	6,2	3,4	1,7	1,1	1,5	0,68	0,69	65	68	27,9	15,5	2000	4 x 1,5	1,7	189196	189209
O4I 200	7,9	4,8	2,2	1,5	2	0,68	0,63	69	72	34,7	18	2000	4 x 1,5	1,7	189197	189210
O4I 300	10,9	6,1	3	2,2	3	0,7	0,69	72	74	56,6	34,2	3000	4 x 1,5	1,7	189198	189203
O4I 400	13,6	7,1	4	3	4	0,73	0,84	75	77	77,5	39,5	5000	4 x 2	2,7	189199	189211
O4I 550	17,6	9,2	5,3	4	5,5	0,74	0,83	76	78	95	49,5	5000	4 x 2	2,7	189200	189212
O4I 750	-	11,7	7	5,5	7,5	-	0,86	-	79	-	64	5000	4 x 2	2,7	-	189213

Dimension and weight

Model	A		B		C Ø máx.	Kg	
	1~	3~	1~	3~		1~	3~
O4I 075	331	331	370	370	94	7,2	7,2
O4I 100	356	356	395	395	94	8,5	8,5
O4I 150	386	371	425	410	94	10,2	9,4
O4I 200	436	386	475	425	94	11,7	10,2
O4I 300	505	450	543	488	94	15,1	11,9
O4I 400	-	520	-	558	94	-	16,2
O4I 550	-	610	-	648	94	-	20,1
O4I 750	-	700	-	738	94	-	24,7

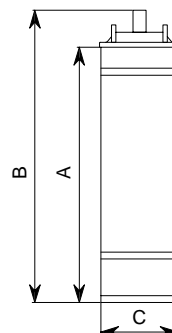

Resin joint



Model	Cables [mm ²]	Code
EC 10	up to 4 x 10	103079
EC 25	up to 4 x 25	103080





Supply

Water when
and where
you need it



Centrifugal single stage pump for water supply, self-priming up to 9m

Applications

Pumping of clean water for domestic, industrial, agricultural and gardening purposes.
Self-priming up to 9m.

Materials

Pump body in AISI 304.
Pump shaft in AISI 431.
Impeller and diffuser in technopolymer.
Delta 1755 impeller in AISI 304.
Mechanical seal.
Motor casing in aluminum.
O-rings in NBR/EPDM.

Equipment

No cable.
Handle included.

Motor

Asynchronous 2 poles.
IPX5 protection.
Class F insulation.
Single phase motor with built-in thermal protection.
Continuous operation.

Range of use

Maximum water temperature 40 °C.



Features table

Model	I [A]			P1 [kW]		P2		c [μF]	l/min									Code	
	1~230V	3~230V	3~400V	1~	3~	[kW]	[HP]			5	15	25	35	40	50	60	75	1-230V	3-230V/400V
Delta 505	2,8	-	-	0,6	-	0,37	0,5	12	mwc	33	26	22	18	17	13	-	-	146271	-
Delta 755	3,4	2,6	1,3	0,8	0,8	0,55	0,75	12		37	32	27	23	21	17	-	-	146270	146309
Delta 1005	4,8	3,6	2,1	1	1	0,75	1	16		47	40	34	29	27	-	-	-	146018	146061
Delta 1755	5,5	-	-	1,2	-	0,75	1	16		57	55	51	47	44	38	32	21	146017	-

Performance curve at 2900 rpm

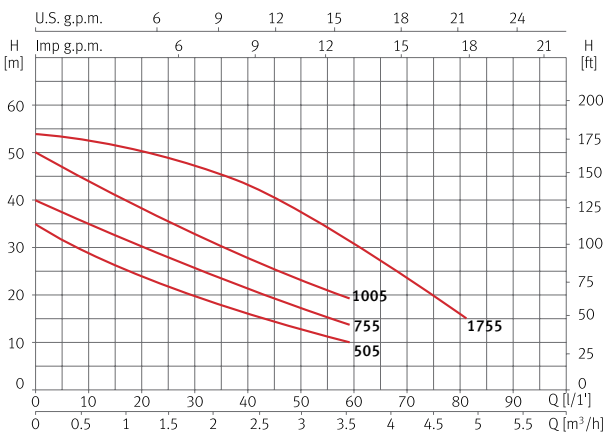

Dimension and weight

Model	A	B	C	D	E	F	G	H	I	Kg
Delta 505	336	215	22	200	1"	78	126	94	147	6,8
Delta 755	336	215	22	200	1"	78	126	94	147	7,3
Delta 1005	359	225	22	200	1"	78	126	94	147	9,6
Delta 1755	410	225	22	200	1"	125	126	94	147	12,1

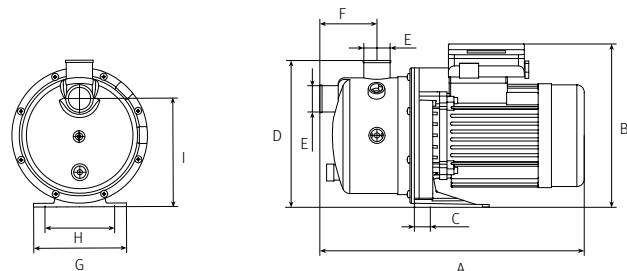

Centrifugal multistage pump for water supply

Applications

Pumping of clean water for domestic, industrial, agricultural and gardening purposes.
Silent.
Self-priming up to 2m.

Materials

Pump body and impellers in AISI 304.
Pump shaft in AISI 431.
Diffusers in technopolymer.
Suction and discharge in cast iron with cataphoresis coating.
Mechanical seal.
Motor casing in aluminum.
O-rings in NBR/EPDM.

Equipment

No cable.

Motor

Asynchronous 2 poles.
IPX5 protection.
Class F insulation.
Single phase motor with built-in thermal protection.
Continuous operation.

Range of use

Maximum water temperature 40 °C.



Stainless steel impellers

High performance

Easy to maintain

Quiet

Best seller

Pressure up to 50 m

Flow rate up to 65 l/min

Features table

Model	I [A]			P1 [kW]		P2		c [μF]	l/min	10	20	30	35	40	50	60	65	Code	
	1~230V	3~230V	3~400V	1~	3~	[kW]	[HP]											m ³ /h	0,6
Prisma 15 2	2	-	-	0,45	-	0,24	0,33	12	mwc	21	20	17	16	14	11	7	5	97134	-
Prisma 15 3	2,8	2,1	1,2	0,61	0,61	0,37	0,5	12		32	30	26	24	22	17	11	7	97141	97138
Prisma 15 4	3,6	2,3	1,3	0,79	0,79	0,55	0,75	12		43	39	35	32	27	22	14	9	97150	97148
Prisma 15 5	4,1	3,3	1,9	0,95	0,95	0,75	1	12		51	47	42	38	34	25	17	12	97159	97157

Performance curve at 2900 rpm

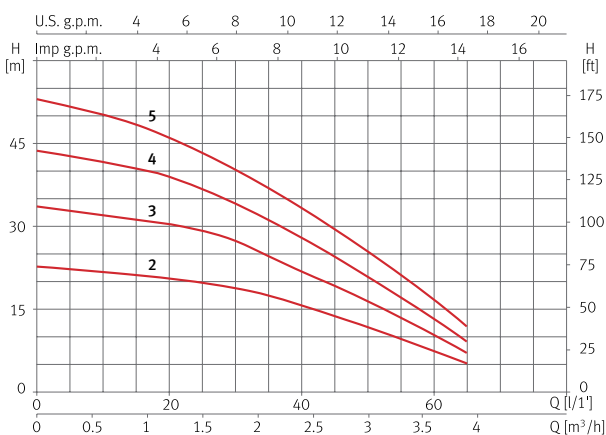

Dimension and weight

Model	A	B	C	D	E	F/G	H	I	J	K	Kg
Prisma 15 2	365	213	202	110	163	1"	121	102	Ø9	162	8,3
Prisma 15 3	389	237	202	110	187	1"	121	102	Ø9	162	9,2
Prisma 15 4	413	261	202	110	211	1"	121	102	Ø9	162	10
Prisma 15 5	437	285	202	110	235	1"	121	102	Ø9	162	11

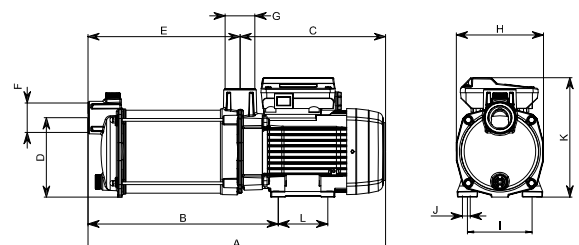

Centrifugal multistage pump for water supply

Applications

Pumping of clean water for domestic, industrial, agricultural and gardening purposes.
Silent.
Self-priming up to 2m.

Materials

Pump body and impellers in AISI 304.
Pump shaft in AISI 431.
Diffusers in technopolymer.
Suction and discharge in cast iron with cataphoresis coating.
Mechanical seal.
Motor casing in aluminum.
O-rings in NBR/EPDM.

Equipment

No cable.

Motor

Asynchronous 2 poles.
IPX5 protection.
Class F insulation.
Single phase motor with built-in thermal protection.
Continuous operation.

Range of use

Maximum water temperature 40 °C.



Stainless steel impellers



Easy to maintain



Quiet



Best seller



Pressure up to 65 m



Flow rate up to 120 l/min

Features table

Model	I [A]			P1 [kW]		P2		c [μF]	l/min	15	30	45	60	75	90	105	120	Code	
	1~230V	3~230V	3~400V	1~	3~	[kW]	[HP]											1~230V	3~230V/400V
Prisma 25 2	4,3	-	-	0,9	-	0,55	0,75	16	mwc	0,9	1,8	2,7	3,6	4,5	5,4	6,3	7,2	97170	-
Prisma 25 3	5,5	3,5	2	1,2	1	0,75	1	16		22	21	20	19	17	15	12	8	97178	97175
Prisma 25 4	6,8	4,3	2,5	1,5	1,4	0,9	1,2	16		33	32	31	28	26	22	17	12	97188	97185
Prisma 25 5	7,4	5,2	3	1,7	1,7	1,1	1,5	30		43	42	40	37	33	28	22	15	97196	97194
Prisma 25 6	9,8	6,7	3,9	2,2	2	1,5	2	30		56	55	53	48	43	37	29	20	97203	97202
										72	68	65	58	50	40	32	24		

Performance curve at 2900 rpm

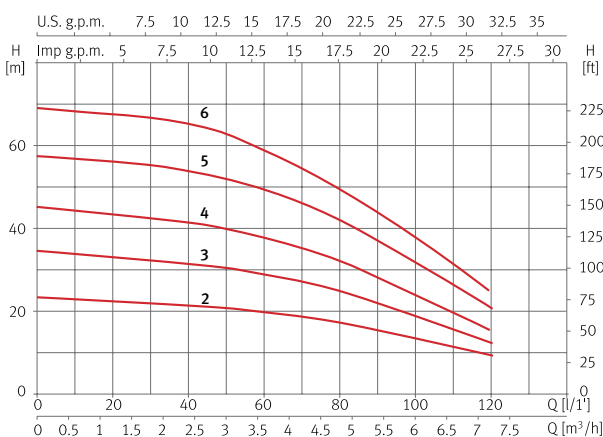

Dimension and weight

Model	A	B	C	D	E	F/G	H	I	J	K	Kg
Prisma 25 2	394	226	218	127	176	1"	138	118	Ø8	185	12,5
Prisma 25 3	403	253	218	127	202	1"	138	118	Ø8	185	13,5
Prisma 25 4	447	279	218	127	229	1"	138	118	Ø8	185	14,6
Prisma 25 5	496	328	241	127	255	1"	138	118	Ø8	212	17,2
Prisma 25 6	567	304	286	142	281	1"	154	118	Ø10	212	20

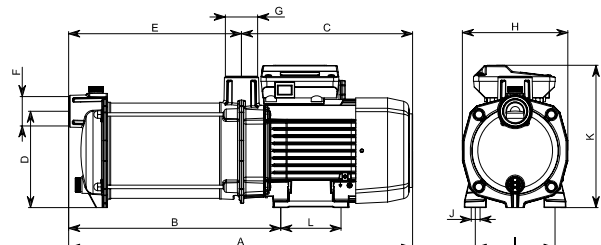

Prisma 35N Supply | Horizontal surface



Centrifugal multistage pump for water supply

Applications

Pumping of clean water for domestic, industrial, agricultural and gardening purposes.
Silent.
Self-priming up to 2m.

Materials

Pump body and impellers in AISI 304.
Pump shaft in AISI 431.
Diffusers in technopolymer.
Suction and discharge in cast iron with cathoresis coating.
Mechanical seal.
Motor casing in aluminum.
O-rings in NBR/EPDM.

Equipment

No cable.

Motor

Asynchronous 2 poles.
IPX5 protection.
Class F insulation.
Single phase motor with built-in thermal protection.
Continuous operation.

Range of use

Maximum water temperature 40 °C.



Stainless steel impellers



Easy to maintain



Quiet



Best seller



Pressure up to 80 m



Flow rate up to 150 l/min

Features table

Model	I [A]			P1 [kW]		P2		c [μF]	l/min m³/h									Code	
	1~230V	3~230V	3~400V	1~	3~	[kW]	[HP]			20	40	60	80	100	120	140	150	1~230V	3~230V/400V
Prisma 35 3N	6,7	4,5	2,6	1,5	1,4	0,75	1	30	mwc	41	39	36	34	31	27	22	18	129343	129346
Prisma 35 4N	8,4	5,3	3,1	1,8	1,8	1,1	1,5	30		54	51	48	44	39	33	27	23	129344	129347
Prisma 35 5N	10,2	6,9	4	2,3	2,2	1,5	2	30		68	64	60	55	49	41	34	30	129345	129348
Prisma 35 6N	-	8,3	4,8	-	2,7	2,2	3	-		81	78	74	67	60	52	42	37	-	129349

Performance curve at 2900 rpm

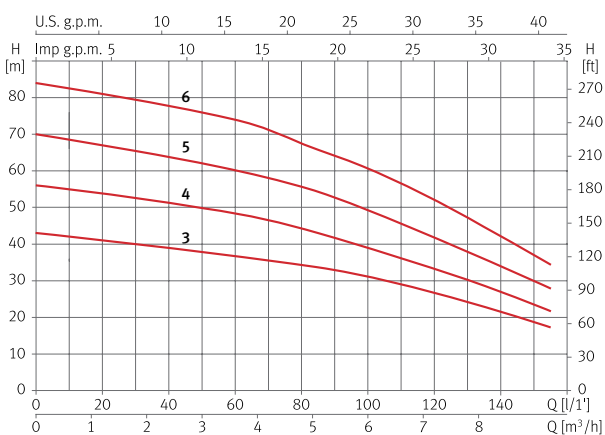

Dimension and weight

Model	A	B	C	D	E	F/G	H	I	J	K	Kg
Prisma 35 3N	503	187	282	147	221	1 1/4"	158	120	Ø12	212	18,5
Prisma 35 4N	529	212	282	147	247	1 1/4"	158	120	Ø12	212	20,5
Prisma 35 5N	553	236	282	147	271	1 1/4"	158	120	Ø12	212	23,5
Prisma 35 6N	578	261	282	147	296	1 1/4"	158	120	Ø12	212	23,7

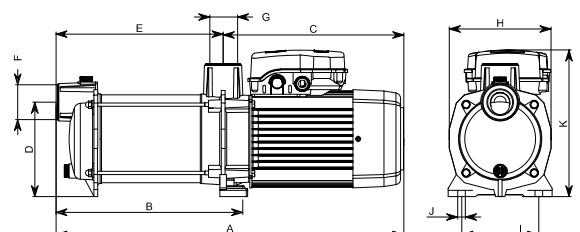

Centrifugal multistage pump for water supply

Applications

Pumping of clean water for domestic, industrial, agricultural and gardening purposes.
Silent.
Self-priming up to 2m.

Materials

Pump body and impellers in AISI 304.
Pump shaft in AISI 431.
Diffusers in technopolymer.
Suction and discharge in cast iron with cathaphoresis coating.
Mechanical seal.
Motor casing in aluminum.
O-rings in NBR/EPDM.

Equipment

No cable.

Motor

Asynchronous 2 poles.
IPX5 protection.
Class F insulation.
Single phase motor with built-in thermal protection.
Continuous operation.

Range of use

Maximum water temperature 40 °C.



Stainless steel impellers	Easy to maintain	Quiet	Best seller	Pressure up to 60 m	Flow rate up to 250 l/min

Features table

Model	I [A]			P1 [kW]		P2		c [μF]	l/min									Code	
	1~230V	3~230V	3~400V	1~	3~	[kW]	[HP]			25	50	75	100	125	150	200	250	1~230V	3~230V/400V
Prisma 45 3N	7,9	5,2	3	1,8	1,7	1,1	1,5	30		1,5	3,0	4,5	6,0	7,5	9,0	12	15	132082	132084
Prisma 45 4N	10	6,9	4	2,2	2,2	1,5	2	30	mwc	37	36	35	33	30	27	18	8	132083	132085
Prisma 45 5N	-	8,6	5	-	2,8	2,2	3	-		48	47	45	42	39	36	24	11	-	132086

Performance curve at 2900 rpm

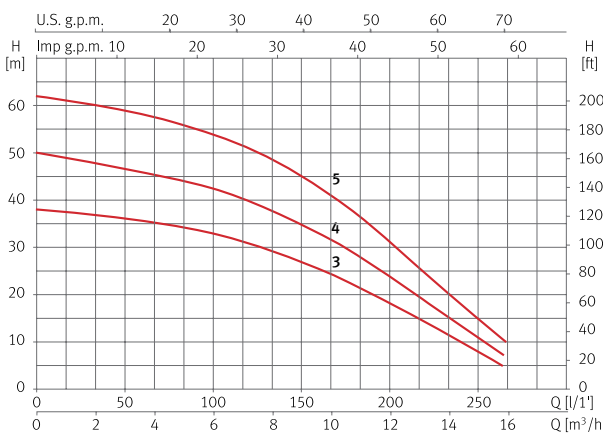

Dimension and weight

Model	A	B	C	D	E	F	G	H	I	J	K	Kg
Prisma 45 3N	528	211	282	147	246	1 ¹ / ₄ "	1 ¹ / ₂ "	158	120	Ø12	218	22,6
Prisma 45 4N	559	242	282	147	277	1 ¹ / ₄ "	1 ¹ / ₂ "	158	120	Ø12	218	23,7
Prisma 45 5N	589	273	282	147	307	1 ¹ / ₄ "	1 ¹ / ₂ "	158	120	Ø12	218	25,3

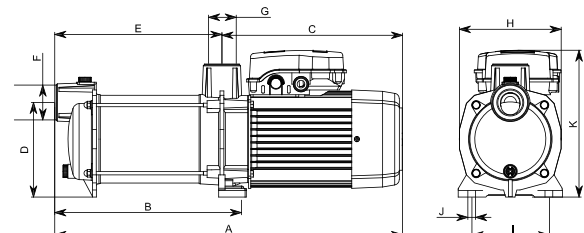

Centrifugal multistage pump for water supply, self-priming up to 9m

Applications

Pumping of clean water for domestic, industrial, agricultural and gardening purposes.
Silent.
Self-priming up to 9m.

Materials

Pump body and impellers in AISI 304.
Pump shaft in AISI 431.
Diffusers in technopolymer.
Suction and discharge in cast iron with cataphoresis coating (Model B in brass).
Mechanical seal.
Motor casing in aluminum.
O-rings in NBR/EPDM.

Equipment

No cable (model B with 2m of cable with plug type F).

Motor

Asynchronous 2 poles.
IPX5 protection.
Class F insulation.
Single phase motor with built-in thermal protection.
Continuous operation.

Range of use

Maximum water temperature 40 °C.



Model B

Stainless steel impellers	Self-priming up to 9 m	High performance	Easy to maintain	Quiet	Pressure up to 50 m	Flow rate up to 65 l/min

Features table

Model	I [A]			P1 [kW]		P2		c [μF]	l/min	Code									
	1~230V	3~230V	3~400V	1~	3~	[kW]	[HP]			m ³ /h	10	20	30	40	50	60	1~230V	1~230V (Model B)	3~230V/400V
Aspri 15 3	2,8	2,1	1,2	0,61	0,61	0,37	0,5	12	mwc	32	30	26	22	17	11	96415	96419	96412	96413
Aspri 15 4	3,6	2,3	1,3	0,7	0,7	0,55	0,75	12		43	39	35	27	22	14	96423	96427	96421	96422
Aspri 15 5	4,1	3,3	1,9	0,95	0,95	0,75	1	12		51	47	42	34	25	17	96432	96436	96430	96431

Performance curve at 2900 rpm

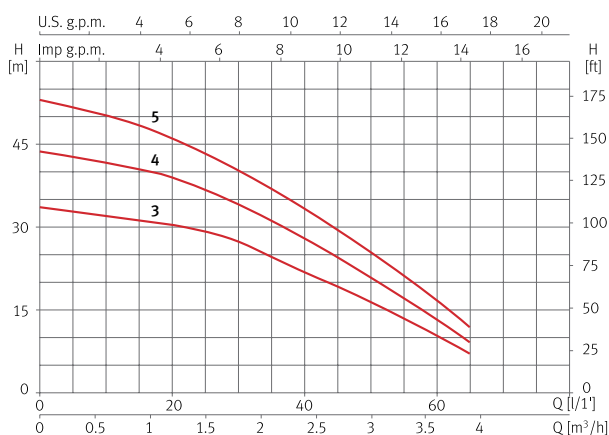

Dimension and weight

Model	A	B	C	D	E	F/G	H	I	J	K	Kg
Aspri 15 3	389	237	202	110	187	1"	121	102	Ø9	162	9,2
Aspri 15 4	413	261	202	110	211	1"	121	102	Ø9	162	10
Aspri 15 5	437	285	202	110	235	1"	121	102	Ø9	162	11

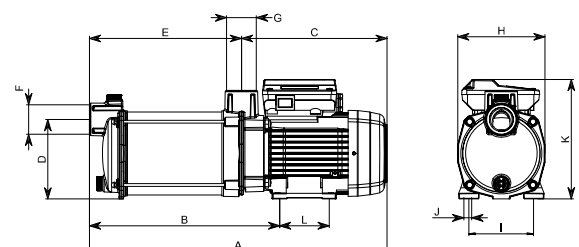

Centrifugal multistage pump for water supply, self-priming up to 9m

Applications

Pumping of clean water for domestic, industrial, agricultural and gardening purposes.
Silent.
Self-priming up to 9m.

Materials

Pump body and impellers in AISI 304.
Pump shaft in AISI 431.
Diffusers in technopolymer.
Suction and discharge in cast iron with cathaphoresis coating.
Mechanical seal.
Motor casing in aluminum.
O-rings in NBR/EPDM.

Equipamiento

2m of cable with plug type F.
ON/OFF switch.

Motor

Asynchronous 2 poles.
IPX5 protection.
Class F insulation.
Single phase motor with built-in thermal protection.
Continuous operation.

Range of use

Maximum water temperature 40 °C.



Stainless steel impellers	Self-priming up to 9 m	Easy to maintain	Quiet	Pressure up to 70 m	Flow rate up to 80 l/min	ON/OFF switch	Suitable for irrigation

Features table

Model	I [A]	P1 [kW]	P2		c [μF]	l/min	10	20	30	40	50	60	70	Code
	1~230V	1~	[kW]	[HP]			m³/h	0,6	1,2	1,8	2,4	3	3,6	
Aspri 20 5	6,8	1,5	0,9	1,2	16	mwC	68	65	60	55	48	40	30	98378

Performance curve at 2900 rpm

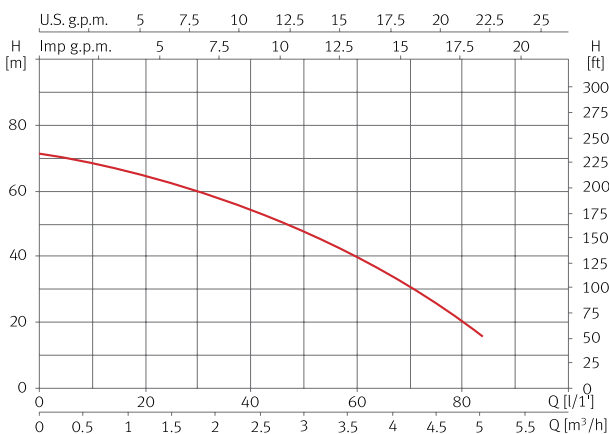

Dimension and weight

Model	A	B	C	D	E	F	G	H	I	J/K	Kg
Aspri 20 5	234	127	278	82	185	8	218	118	138	1"	15,5

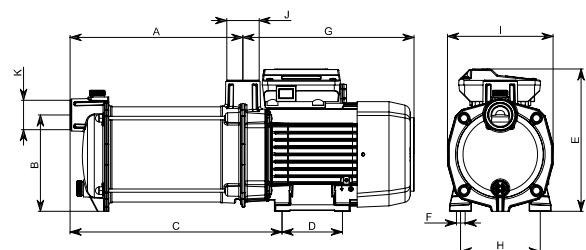

Centrifugal multistage pump for water supply, self-priming up to 9m

Applications

Pumping of clean water for domestic, industrial, agricultural and gardening purposes.
Silent.
Self-priming up to 9m.

Materials

Pump body and impellers in AISI 304.
Pump shaft in AISI 431.
Diffusers in technopolymer.
Suction and discharge in cast iron with cataphoresis coating (Model B in brass).
Mechanical seal.
Motor casing in aluminum.
O-rings in NBR/EPDM.

Equipment

No cable (model B 2m of cable with plug type F).

Motor

Asynchronous 2 poles.
IPX5 protection.
Class F insulation.
Single phase motor with built-in thermal protection.
Continuous operation.

Range of use

Maximum water temperature 40 °C.



Model B



Stainless steel impellers



Self-priming up to 9 m



Easy to maintain



Quiet



Pressure up to 55 m



Flow rate up to 120 l/min

Features table

Model	I [A]			P1 [kW]		P2		c [μF]	l/min	20	40	60	80	100	120	Code			
	1~230V	3~230V	3~400V	1~	3~	[kW]	[HP]									m³/h	1,2	2,4	3,6
Aspri 25 3	5,5	3,5	2	1,1	1	0,75	1	16	mwc	33	31	28	25	19	12	96450	96452	96447	-
Aspri 25 4	6,8	4,3	2,5	1,5	1,4	0,9	1,2	16		43	41	37	33	23	15	96458	96462	96455	96456
Aspri 25 5	7,4	5,2	3	1,7	1,7	1,1	1,5	30		56	54	48	42	31	20	96466	96468	96464	96465

Performance curve at 2900 rpm

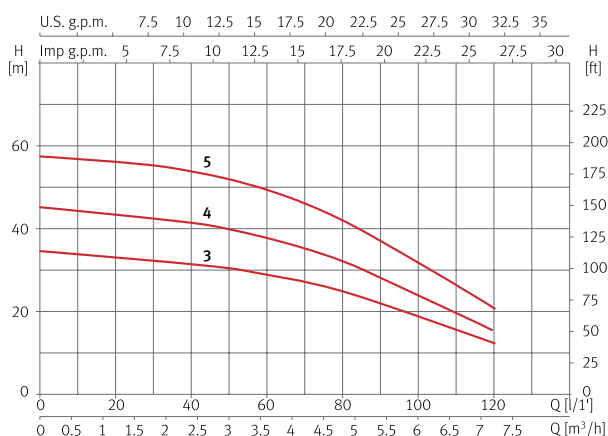

Dimension and weight

Model	A	B	C	D	E	F/G	H	I	J	K	Kg
Aspri 25 3	403	253	218	127	202	1"	138	118	Ø8	185	13,5
Aspri 25 4	447	279	218	127	229	1"	138	118	Ø8	185	14,6
Aspri 25 5	496	328	241	127	255	1"	138	118	Ø8	212	17,2

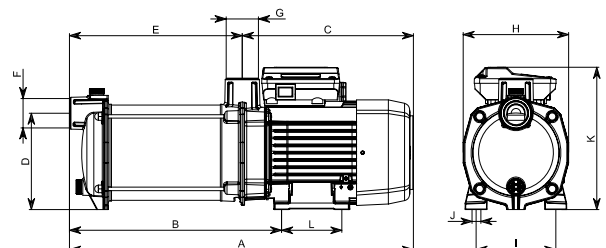

Centrifugal multistage pump for water supply, self-priming up to 9m

Applications

Pumping of clean water for domestic, industrial, agricultural and gardening purposes.
Silent.
Self-priming up to 9m.

Materials

Pump body and impellers in AISI 304.
Pump shaft in AISI 431.
Diffusers in technopolymer.
Suction and discharge in cast iron with cathaphoresis coating.
Mechanical seal.
Motor casing in aluminum.
O-rings in NBR/EPDM.

Equipment

No cable.

Motor

Asynchronous 2 poles.
IPX5 protection.
Class F insulation.
Single phase motor with built-in thermal protection.
Continuous operation.

Range of use

Maximum water temperature 40 °C.



Stainless steel impellers



Self-priming up to 9 m



Easy to maintain



Quiet



Pressure up to 80 m



Flow rate up to 150 l/min

Features table

Model	I [A]			P1 [kW]		P2		c [μF]	l/min m³/h	20	40	60	80	100	120	140	150	Code	
	1~230V	3~230V	3~400V	1~	3~	[kW]	[HP]			1,2	2,4	3,6	4,8	6,0	7,2	8,4	9,0	1~230V	3~230V/400V
Aspri 35 3N	6,7	4,5	2,6	1,5	1,4	0,75	1	30	41	39	36	34	31	27	22	18	129699	129696	
Aspri 35 4N	8,4	5,3	3,1	1,8	1,8	1,1	1,5	30	54	51	48	44	39	33	27	23	129700	129697	
Aspri 35 5N	10,2	6,9	4	2,3	2,2	1,5	2	30	68	64	60	55	49	41	34	30	129701	129698	
Aspri 35 6N	-	8,3	4,8	-	2,7	2,2	3	-	81	78	74	67	60	52	42	37	-	130368	

Performance curve at 2900 rpm

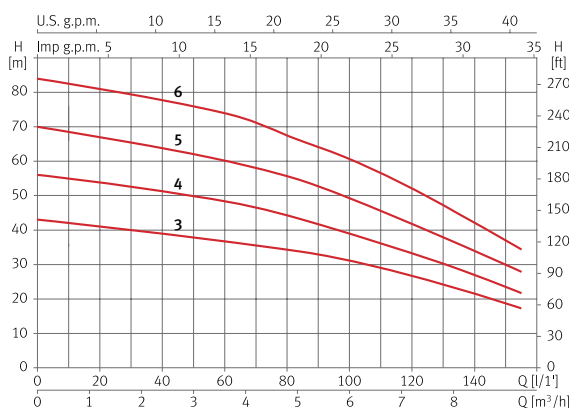

Dimension and weight

Model	A	B	C	D	E	F/G	H	I	J	K	Kg
Aspri 35 3N	503	187	282	147	221	1 ^{1/4} "	158	120	Ø12	212	18,5
Aspri 35 4N	529	212	282	147	247	1 ^{1/4} "	158	120	Ø12	212	20,5
Aspri 35 5N	553	236	282	147	271	1 ^{1/4} "	158	120	Ø12	212	23,5
Aspri 35 6N	578	261	282	147	296	1 ^{1/4} "	158	120	Ø12	212	23,7

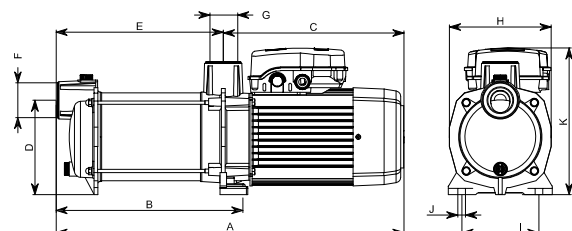

Aspri 45N Supply | Horizontal surface



Centrifugal multistage pump for water supply, self-priming up to 9m

Applications

Pumping of clean water for domestic, industrial, agricultural and gardening purposes.
Silent.
Self-priming up to 9m.

Materials

Pump body and impellers in AISI 304.
Pump shaft in AISI 431.
Diffusers in technopolymer.
Suction and discharge in cast iron with cataphoresis coating.
Mechanical seal.
Motor casing in aluminum.
O-rings in NBR/EPDM.

Equipment

No cable.

Motor

Asynchronous 2 poles.
IPX5 protection.
Class F insulation.
Single phase motor with built-in thermal protection.
Continuous operation.

Range of use

Maximum water temperature 40 °C.



Stainless steel impellers



Self-priming up to 9 m



Easy to maintain



Quiet



Pressure up to 60 m



Flow rate up to 250 l/min

Features table

Model	I [A]			P1 [kW]		P2		c [μF]	l/min m³/h	25	50	75	100	125	150	200	250	Code	
	1~230V	3~230V	3~400V	1~	3~	[kW]	[HP]											1~230V	3~230V/400V
Aspri 45 3N	7,9	5,2	3	1,8	1,7	1,1	1,5	30	mwc	37	36	35	33	30	27	18	8	132087	132089
Aspri 45 4N	10	6,9	4	2,2	2,2	1,5	2	30		48	47	45	42	39	36	24	11	132088	132090
Aspri 45 5N	-	8,6	5	-	2,8	2,2	3	-		61	59	56	54	50	45	31	15	-	132091

Performance curve at 2900 rpm

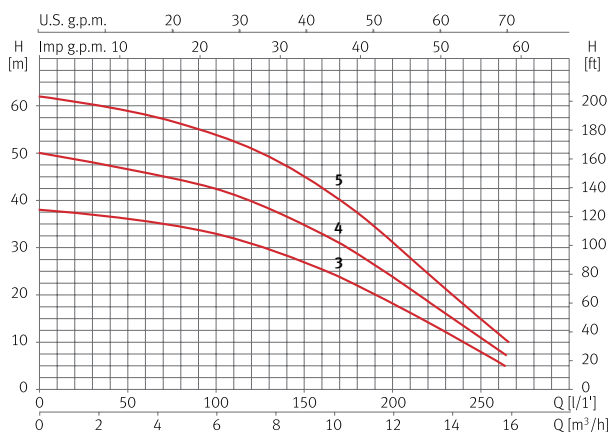

Dimension and weight

Model	A	B	C	D	E	F	G	H	I	J	K	Kg
Aspri 45 3N	528	211	282	147	246	1 1/4"	1 1/2"	158	120	Ø12	218	22,6
Aspri 45 4N	559	242	282	147	277	1 1/4"	1 1/2"	158	120	Ø12	218	23,7
Aspri 45 5N	589	273	282	147	307	1 1/4"	1 1/2"	158	120	Ø12	218	25,3

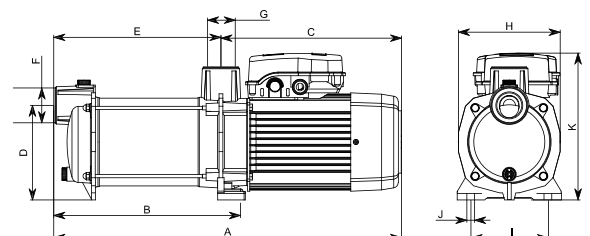

Centrifugal multistage pump for water supply

Applications

Pumping of clean water for domestic, industrial, agricultural and gardening purposes.
Silent.
Self-priming up to 2m.

Motor

Asynchronous 2 poles.
IPX5 protection.
Class F insulation.
Built-in thermal protection.
Continuous operation.

Materials

Pump body and impellers in AISI 304.
Pump shaft in AISI 431.
Diffusers in technopolymer.
Mechanical seal.
Motor casing in aluminum.
O-rings in NBR/EPDM.

Range of use

Maximum water temperature 40 °C.

Equipment

No cable.



Stainless steel impellers	Easy to maintain	Quiet	Pressure up to 40 m	Flow rate up to 35 l/min

Features table

Model	I [A]	P1 [kW]	P2		c [μF]	l/min	5	10	15	20	25	30	35	37	Code
	1~230V	1~	[kW]	[HP]			m ³ /h	0,3	0,6	0,9	1,2	1,5	1,8	2,1	
Tecno 05 2	1,2	0,25	0,11	0,15	6	mwc	18	17	15	13	10	7	3	1	97502
Tecno 05 3	1,6	0,35	0,19	0,25	6		27	26	23	20	17	12	7	4	97505
Tecno 05 4	2	0,45	0,19	0,25	6		36	33	30	26	21	16	10	7	97508

Performance curve at 2900 rpm

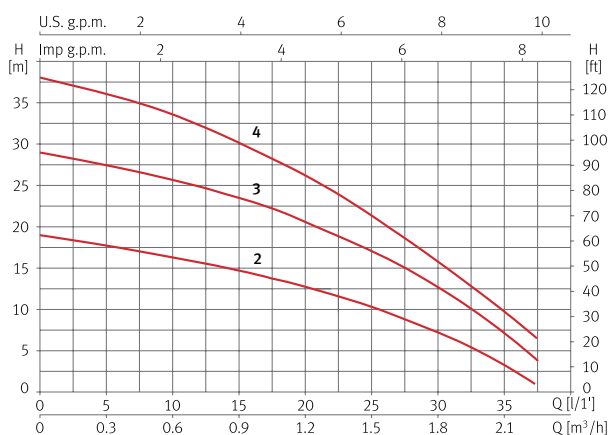

Dimension and weight

Model	A	B	C	D	E/F	G	H	I	J	Kg
Tecno 05 2	176	124	225	94	1"	136	174	80	Ø9	5,2
Tecno 05 3	194	142	225	94	1"	136	174	80	Ø9	6,2
Tecno 05 4	212	159	225	94	1"	136	174	80	Ø9	6,3

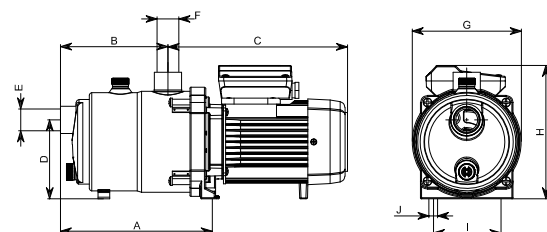

Centrifugal multistage pump for water supply, self-priming up to 9m

Applications

Pumping of clean water for domestic, industrial, agricultural and gardening purposes.
Silent.
Self-priming up to 9m.

Materials

Pump body and impellers in AISI 304.
Pump shaft in AISI 431.
Diffusers in technopolymer.
Mechanical seal.
Motor casing in aluminum.
O-rings in NBR/EPDM.

Equipment

No cable.

Motor

Asynchronous 2 poles.
IPX5 protection.
Class F insulation.
Single phase motor with built-in thermal protection.
Continuous operation.

Range of use

Maximum water temperature 40 °C.



Stainless steel impellers



Self-priming up to 9 m



High performance



Easy to maintain



Quiet



Pressure up to 50 m



Flow rate up to 65 l/min

Features table

Model	I [A]			P1 [kW]		P2		c [μF]	l/min								Code		
	1~ 230V	3~ 230V	3~ 400V	1~	3~	[kW]	[HP]			10	20	30	35	40	50	60	65	1~230V	3~230V/400V
Tecno 15 3	2,8	2,1	1,2	0,61	0,61	0,37	0,5	12	mwc	32	30	26	24	22	17	11	7	97518	97515
Tecno 15 4	3,6	2,3	1,3	0,8	0,79	0,45	0,6	12		43	39	35	32	27	22	14	9	97520	97519
Tecno 15 5	4,1	3,3	1,9	0,95	0,95	0,75	1	12		51	47	42	38	34	25	17	12	97522	97521

Performance curve at 2900 rpm

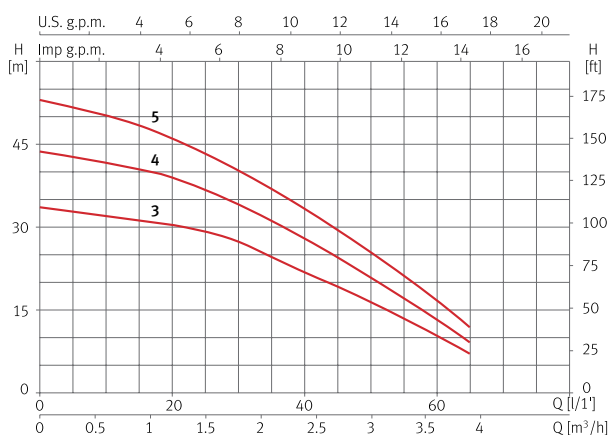

Dimension and weight

Model	A	B	C	D	E/F	G	H	I	J	Kg
Tecno 15 3	258	197	233	108	1"	148	196	88	Ø9	8,4
Tecno 15 4	281	221	233	108	1"	148	196	88	Ø9	8,8
Tecno 15 5	305	244	233	108	1"	148	196	88	Ø9	9,5

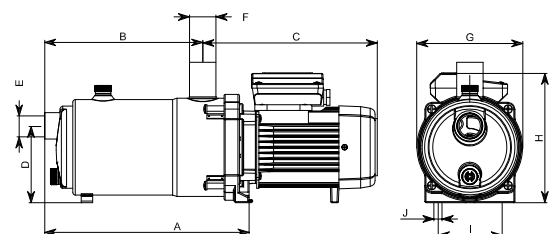

Centrifugal multistage pump for water supply, self-priming up to 9m

Applications

Pumping of clean water for domestic, industrial, agricultural and gardening purposes.
Silent.
Self-priming up to 9m.

Materials

Pump body and impellers in AISI 304.
Pump shaft in AISI 431.
Diffusers in technopolymer.
Mechanical seal.
Motor casing in aluminum.
O-rings in NBR/EPDM.

Equipment

No cable.

Motor

Asynchronous 2 poles.
IPX5 protection.
Class F insulation.
Single phase motor with built-in thermal protection.
Continuous operation.

Range of use

Maximum water temperature 40 °C.



Impellers and body in stainless steel	Self-priming up to 9 m	Easy to maintain	Quiet	Pressure up to 55 m	Flow rate up to 120 l/min

Features table

Model	I [A]			P1 [kW]		P2		c [μF]	l/min	15	30	45	60	75	90	105	120	Code	
	1~230V	3~230V	3~400V	1~	3~	[kW]	[HP]			m³/h	0,9	1,8	2,7	3,6	4,5	5,4	6,3	7,2	1~230V
Tecno 25 3	5,5	-	-	1,2	-	0,75	1	16	mwc	33	32	31	28	26	22	17	12	97526	-
Tecno 25 4	6,8	4,3	2,5	1,5	1,4	0,9	1,2	16		43	42	40	37	33	28	22	15	97528	97527
Tecno 25 5	7,4	5,2	3	1,7	1,7	1,1	1,5	30		56	55	53	48	43	37	29	20	97530	97529

Performance curve at 2900 rpm

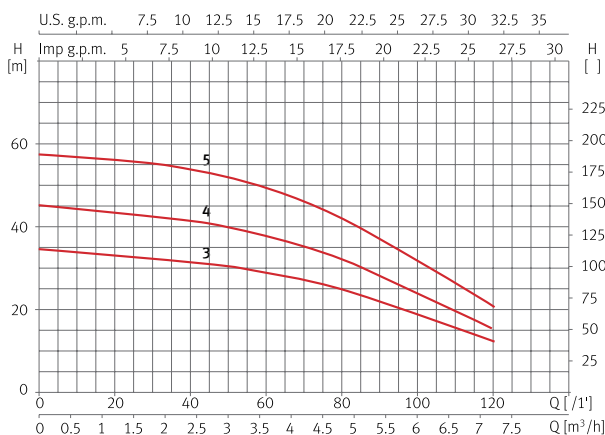

Dimension and weight

Model	A	B	C	D	E/F	G	H	I	J	Kg
Tecno 25 3	272	210	267	108	1"	149	196	88	Ø9	7,2
Tecno 25 4	298	237	267	108	1"	149	196	88	Ø9	9,5
Tecno 25 5	325	263	289	108	1"	149	196	88	Ø9	11

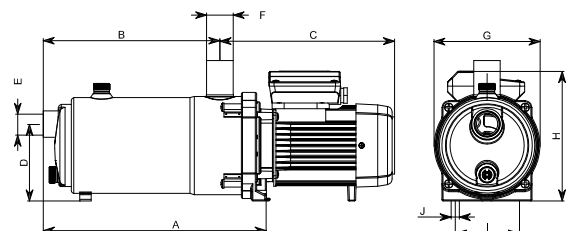

Centrifugal multistage pump for water supply

Applications

Pumping of clean water for domestic, industrial, agricultural and gardening purposes.
Silent.

Materials

Pump body and impellers in AISI 304.
Pump shaft in AISI 420.
Diffusers in technopolymer.
Suction and discharge in cast iron with cataphoresis coating.
Mechanical seal.
Motor casing in aluminum.
O-rings in NBR/EPDM.

Equipment

No cable.
Oval counter flanges DIN 2558 and gaskets included.

Motor

Asynchronous 2 poles.
IPX5 protection.
Class F insulation.
Single phase motor with built-in thermal protection.
Continuous operation.

Range of use

Maximum water temperature 40 °C.



Stainless steel impellers	Easy to maintain	Quiet	Pressure up to 70 m	Flow rate up to 85 l/min

Features table

Model	I [A]			P1 [kW]		P2		c [μF]	l/min									Code	
	1~230V	3~230V	3~400V	1~	3~	[kW]	[HP]			m ³ /h	8	17	25	33	42	58	75	85	1~230V
Multi 25 4	5,5	3,6	2,1	1,2	1,1	0,75	1	16	mwc	0,5	1,0	1,5	2,0	2,5	3,5	4,5	5,1	134927	134930
Multi 25 5	6	4,3	2,5	1,3	1,3	0,9	1,2	16		0,5	1,0	1,5	2,0	2,5	3,5	4,5	5,1	134928	134931

Performance curve at 2900 rpm

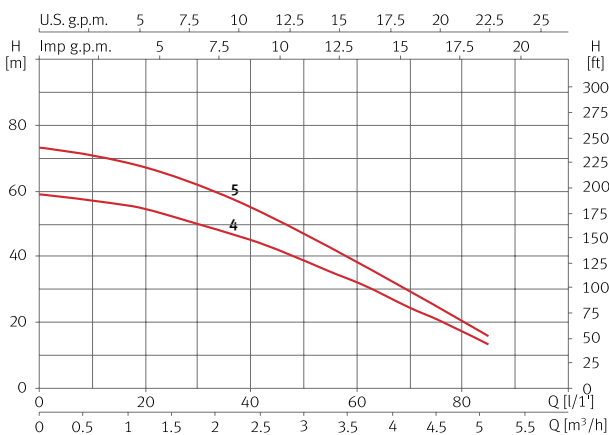

Dimension and weight

Model	A	B	C	D	E	F	G	H	I	J	K	Kg
Multi 25 4	420	205	170	42	203	191	1 1/4"	1 1/4"	125	125	240	16,5
Multi 25 5	442	226	170	42	203	191	1 1/4"	1 1/4"	125	125	240	17,6

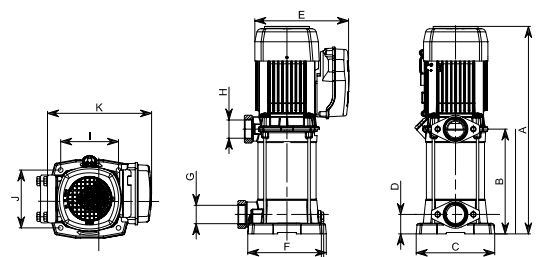

Centrifugal multistage pump for water supply

Applications

Pumping of clean water for domestic, industrial, agricultural and gardening purposes.
Silent.

Materials

Pump body and impellers in AISI 304.
Pump shaft in AISI 420.
Diffusers in technopolymer.
Suction and discharge in cast iron with cathaphoresis coating.
Mechanical seal.
Motor casing in aluminum.
O-rings in NBR/EPDM.

Equipment

No cable.
Oval counter flanges DIN 2558 and gaskets included.

Motor

Asynchronous 2 poles.
IPX5 protection.
Class F insulation.
Single phase motor with built-in thermal protection.
Continuous operation.

Range of use

Maximum water temperature 40 °C.



Stainless steel impellers	Easy to maintain	Quiet	Pressure up to 135 m	Flow rate up to 175 l/min

Features table

Model	I [A]			P1 [kW]		P2		c [μF]	l/min	17	33	50	75	100	125	150	175	Code	
	1~230V	3~230V	3~400V	1~	3~	[kW]	[HP]											1~230V	3~230V/400V
Multi 35 3N	6,7	4,5	2,6	1,5	1,4	0,75	1	30	mwc	39	37	35	31	27	21	15	7	129334	129338
Multi 35 4N	8,4	5,3	3,1	1,8	1,8	1,1	1,5	30		54	51	48	44	37	29	21	12	129335	129339
Multi 35 5N	10,2	6,9	4	2,3	2,2	1,5	2	30		65	63	60	54	46	36	26	15	129336	129340
Multi 35 6N	-	8,3	4,8	-	2,7	2,2	3	-		82	80	76	69	61	49	37	23	-	129341
Multi 35 8N	-	11,9	6,5	-	3,6	3	4	-		108	105	101	93	85	70	53	35	-	129342
Multi 35 10N	-	15,4	8,9	-	4,9	4	5,5	-		134	130	125	117	105	90	70	47	-	129337

Performance curve at 2900 rpm

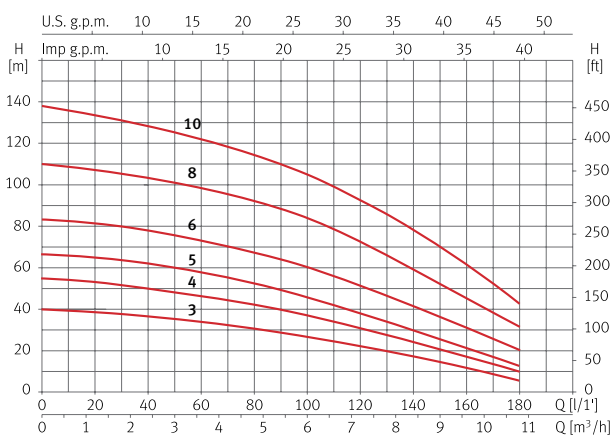

Dimension and weight

Model	A	B	C	D	E	F	G	H	I	J	K	Kg
Multi 35 3N	487	202	184	37	220	207	1 1/2"	1 1/4"	133	133	264	21,4
Multi 35 4N	512	226	184	37	220	207	1 1/2"	1 1/4"	133	133	264	23,2/21,5
Multi 35 5N	536	251	184	37	220	207	1 1/2"	1 1/4"	133	133	264	25,1/22,7
Multi 35 6N	561	275	184	37	220	207	1 1/2"	1 1/4"	133	133	264	25,7
Multi 35 8N	658	323	184	37	236	207	1 1/2"	1 1/4"	133	133	264	32,6
Multi 35 10N	708	373	184	37	236	207	1 1/2"	1 1/4"	133	133	264	39,4

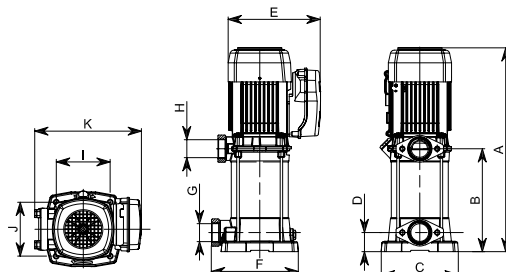

Multi 55N **Supply** | Vertical surface



Centrifugal multistage pump for water supply

Applications

Pumping of clean water for domestic, industrial, agricultural and gardening purposes.
Silent.

Materials

Pump body and impellers in AISI 304.
Pump shaft in AISI 420.
Diffusers in technopolymer.
Suction and discharge in cast iron with cataphoresis coating.
Mechanical seal.
Motor casing in aluminum.
O-rings in NBR/EPDM.

Equipment

No cable.
Oval counter flanges DIN 2558 and gaskets included.

Motor

Asynchronous 2 poles.
IPX5 protection.
Class F insulation.
Single phase motor with built-in thermal protection.
Continuous operation.

Range of use

Maximum water temperature 40 °C.



Stainless steel impellers	Easy to maintain	Quiet	Pressure up to 90 m	Flow rate up to 300 l/min

Features table

Model	I [A]			P1 [kW]		P2		c [μF]	l/min	20	50	75	100	150	200	250	300	Code	
	1~230V	3~230V	3~400V	1~	3~	[kW]	[HP]											m³/h	1,2
Multi 55 3N	9,6	6,6	3,8	2,1	2,1	1,5	2	30	mwc	37	35	33	31	28	24	18	10	131483	131484
Multi 55 4N	-	8,3	4,8	-	2,8	2,2	3	-		50	47	45	43	39	33	26	16	-	131485
Multi 55 6N	-	12,1	7	-	4,2	3	4	-		77	73	70	66	60	52	43	29	-	131486
Multi 55 7N	-	15,6	9	-	4,9	4	5,5	-		90	86	82	78	70	60	50	35	-	131487

Performance curve at 2900 rpm

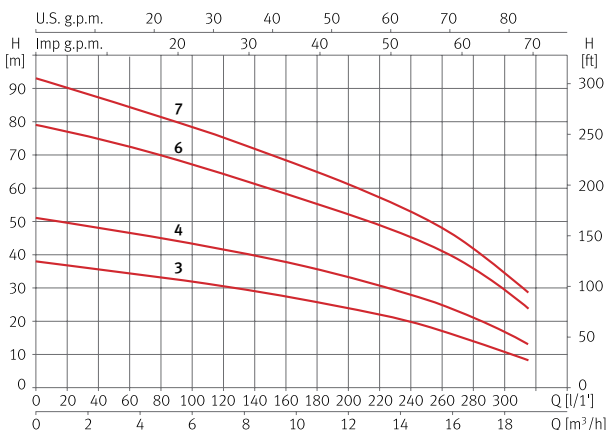

Dimension and weight

Model	A	B	C	D	E	F	G	H	I	J	K	Kg
Multi 55 3N	531	245	184	37	235,5	207	1 1/2"	1 1/4"	133	133	264	25,7/23,3
Multi 55 4N	571	285	184	37	235,5	207	1 1/2"	1 1/4"	133	133	264	26,6
Multi 55 6N	696	362	184	37	235,5	207	1 1/2"	1 1/4"	133	133	264	35,4
Multi 55 7N	736	402	184	37	235,5	207	1 1/2"	1 1/4"	133	133	264	39,7

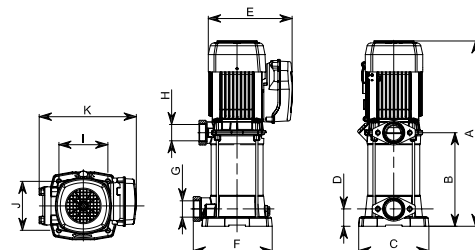

Centrifugal multistage pump in-line for water supply

Applications

Pumping of clean water for domestic, industrial, agricultural and gardening purposes.

Materials

Pump body and impellers in AISI 304.
 Pump shaft in AISI 420.
 Diffusers in technopolymer.
 Suction, discharge and motor-wet end coupling in cast iron.
 Mechanical seal.
 Motor casing in aluminum.
 O-rings in NBR/EPDM.

Equipment

No cable.
 Counter flanges and gaskets included.
 Motor-wet end coupling system V18-flange C (IEC standard).

Motor

Asynchronous 2 poles.
 IPX4 protection.
 Class F insulation.
 Continuous operation.

Range of use

Maximum water temperature 40 °C.



Stainless steel impellers	Inline connection	Pressure up to 135 m	Flow rate up to 225 l/min

Features table

Model	I [A]			P1 [kW]	P2		l/min									Code	
	3~230V	3~400V	3~692V	3~	[kW]	[HP]		m³/h	0	50	100	125	150	175	200	225	3~230V/400V
VE 94 6	6,7	3,9	-	2,3	1,5	2	mwc	58	55	49	44	38	31	22	13	97746	-
VE 94 8	8,9	5,2	-	3	2,2	3		77	73	63	56	49	40	30	18	97759	-
VE 94 10	11,7	6,8	-	3,9	3	4		95	91	81	72	62	50	36	22	97710	-
VE 94 11	12,4	7,2	-	4,4	3	4		108	102	91	82	70	56	42	26	97717	-
VE 94 13	-	8,6	5	5	4	5,5		125	120	107	97	85	68	51	32	-	97726
VE 94 14	-	9,4	5,4	5,5	5,5	7,5		135	129	118	109	95	77	57	35	-	97729

Performance curve at 2900 rpm

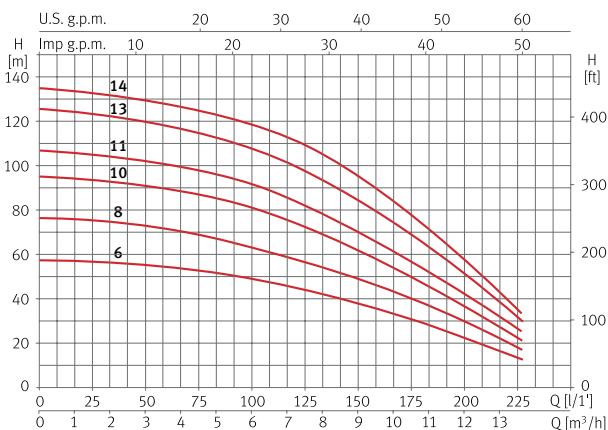

Dimension and weight

Model	A	B	C	D	E	F	G	Kg
VE 94 6	486	738	176	127	200	190	155	35
VE 94 8	563	838	176	127	200	190	155	47
VE 94 10	666	974	194	138	280	190	155	61
VE 94 11	703	1010	194	138	280	190	155	62
VE 94 13	780	1086	194	138	280	190	155	68
VE 94 14	816	1134	220	146	280	190	155	76

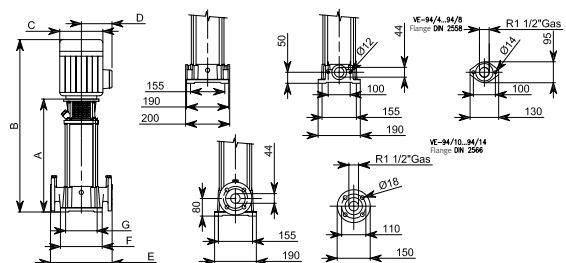

Centrifugal multistage pump in-line for water supply

Applications

Pumping of clean water for domestic, industrial, agricultural and gardening purposes.

Materials

Pump body and impellers in AISI 304.
 Pump shaft in AISI 420.
 Diffusers in technopolymer.
 Suction, discharge and motor-wet end coupling in cast iron.
 Mechanical seal.
 Motor casing in aluminum.
 O-rings in NBR/EPDM.

Equipment

No cable.
 Counter flanges and gaskets included.
 Motor-wet end coupling system V1-flange FF (IEC standard).

Motor

Asynchronous 2 poles.
 IPX4 protection.
 Class F insulation.
 Continuous operation.

Range of use

Maximum water temperature 40 °C.



Stainless steel impellers	Inline connection	Pressure up to 160 m	Flow rate up to 450 l/min

Features table

Model	I [A]			P1 [kW]	P2		l/min	mwc								Code	
	3~230V	3~400V	3~692V	3~	[kW]	[HP]		0	65	130	195	260	325	390	455	3~230V/400V	3~400V/692V
VE 121 2N	-	6	-	3	3	4	33	33	32	31	28	25	20	14	203425	-	
VE 121 3N	-	7	4	4,2	4	5,5	50	49	48	46	42	37	31	21	203426	203427	
VE 121 4N	-	10,1	5,8	5,5	5,5	7,5	66	66	64	61	57	50	41	29	203428	203429	
VE 121 5N	-	11,8	7,7	6,8	5,5	7,5	83	82	80	77	71	62	51	36	203430	203431	
VE 121 6N	-	14,6	8,5	7,8	7,5	10	100	99	96	92	85	75	61	43	-	203433	
VE 121 7N	-	16,5	9,5	9,2	9,2	12,5	116	115	112	107	99	87	71	50	-	203434	
VE 121 8N	-	19,5	11,3	10,6	11	15	133	132	128	123	113	100	81	57	-	203435	
VE 121 9N	-	21	12,2	13,8	15	20	150	148	145	138	127	112	92	64	-	203436	
VE 121 10N	-	23	13,3	15	15	20	166	165	161	153	141	125	102	71	-	203437	

Performance curve at 2900 rpm

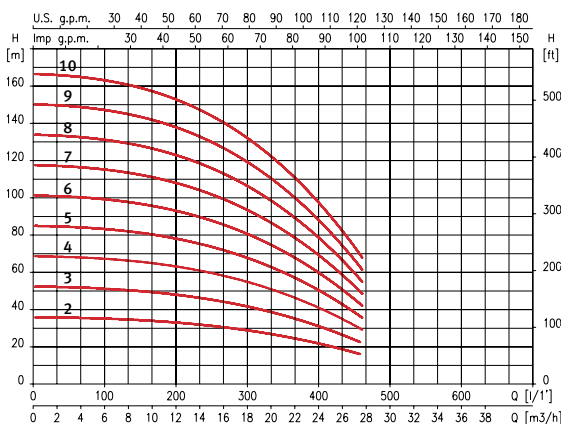

Dimension and weight

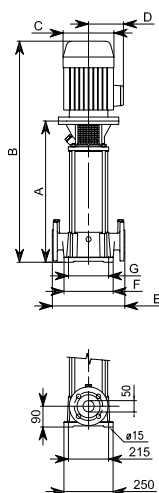

Model	A	B	C	D	E	F	G	Kg
VE 121 2N	470	776	195	140	300	210	130	73
VE 121 3N	522	847	195	140	300	210	130	80
VE 121 4N	574	943	220	182	300	210	130	97
VE 121 5N	626	995	220	182	300	210	130	98
VE 121 6N	678	1085	220	182	300	210	130	107
VE 121 7N	730	1137	220	182	300	210	130	115
VE 121 8N	782	1189	220	182	300	210	130	121
VE 121 9N	834	1241	220	182	300	210	130	187
VE 121 10N	886	1293	220	182	300	210	130	226

Multi VS 05 Supply | Vertical surface



Centrifugal multistage pump in-line for water supply, 100% stainless steel

Applications

Pumping of clean water for domestic, industrial, agricultural and gardening purposes.

Materials

Pump body, suction, discharge, diffusers and impellers in AISI 304.
Pump shaft in AISI 420.
Mechanical seal.
Motor casing in aluminum.
O-rings in FPM.

Equipment

No cable.
Counter flanges not included.
Motor-wet end coupling system V18-flange C (IEC standard).

Motor

Asynchronous 2 poles.
IPX4 protection.
Class F insulation.
Continuous operation.

Range of use

Maximum water temperature 120 °C.



100% stainless steel	Inline connection	Temperature up to 120°	Pressure up to 130 m	Flow rate up to 140 l/min

Features table

Model	Motor				Multi VS hydraulic data										Code
	I [A]		P2		l/min	0	42	50	67	83	100	117	133	142	
	3~230V	3~400V	[kW]	[HP]	m³/h	0	2,5	3	4	5	6	7	8	8,5	
Multi VS 05 06	4,1	2,4	1,1	1,5	mwc	44	42	41	40	37	33	27	21	18	200128
Multi VS 05 09	5,5	3,2	1,5	2		67	64	63	60	55	49	41	31	27	200129
Multi VS 05 10	5,5	3,2	1,5	2		74	71	70	66	62	55	46	35	30	200130
Multi VS 05 11	5,5	3,2	1,5	2		82	78	77	73	68	61	51	39	33	200131
Multi VS 05 12	7,9	4,6	2,2	3		89	85	84	81	74	66	55	43	37	200132
Multi VS 05 14	7,9	4,6	2,2	3		104	100	98	93	87	77	65	51	43	200133
Multi VS 05 18	10	6,2	3	4		134	128	126	120	111	99	84	66	56	200134

Performance curve at 2900 rpm

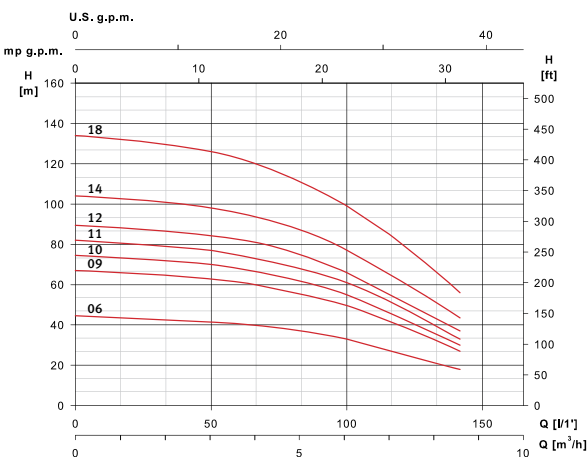

Dimension and weight

Model	Motor		Pump Multi VS		
	E1	E2	F1	F2	Kg
Multi VS 05 06	155	130	639	394	27
Multi VS 05 09	175	136	765	485	33
Multi VS 05 10	175	136	792	512	34
Multi VS 05 11	175	136	819	539	34
Multi VS 05 12	185	145	876	566	37
Multi VS 05 14	185	145	930	620	38
Multi VS 05 18	215	170	1058	738	50

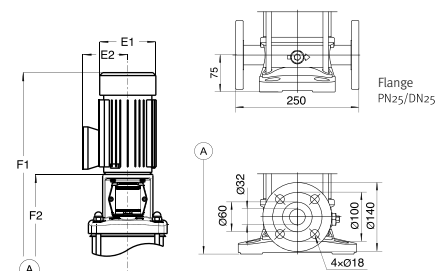

Multi VS 10 **Supply | Vertical surface**



Centrifugal multistage pump in-line for water supply, 100% stainless steel

Applications

Pumping of clean water for domestic, industrial, agricultural and gardening purposes.

Materials

Pump body, suction, discharge, diffusers and impellers in AISI 304.
Pump shaft in AISI 420.
Mechanical seal.
Motor casing in aluminum.
O-rings in FPM.

Equipment

No cable.
Counter flanges not included.
Motor-wet end coupling system V18-flange C (IEC standard).

Motor

Asynchronous 2 poles.
IPX4 protection.
Class F insulation.
Continuous operation.

Range of use

Maximum water temperature 120 °C.



100% stainless steel	Inline connection	Temperature up to 120 ^o	Pressure up to 140 m	Flow rate up to 230 l/min

Features table

Model	Motor					Multi VS hydraulic data								Code	
	I [A]			P2		l/min	0	83	100	133	167	200	233	Code	
	3~230V	3~400V	3~692V	[kW]	[HP]									3~230V/400V	3~400V/692V
Multi VS 10 04	5,5	3,2	-	1,5	2	mwc	44	42	41	38	34	29	22	200136	-
Multi VS 10 06	7,9	4,6	-	2,2	3		67	63	62	58	52	44	34	200137	-
Multi VS 10 07	10	6,2	-	3	4		78	74	73	69	62	52	40	200138	-
Multi VS 10 08	10	6,2	-	3	4		90	85	84	79	71	60	46	200139	-
Multi VS 10 09	-	8,2	4,7	4	5,5		101	96	94	89	80	67	52	-	200140
Multi VS 10 11	-	8,2	4,7	4	5,5		124	118	115	108	98	84	64	-	200141
Multi VS 10 13	-	11,2	6,5	5,5	7,5		147	140	138	130	116	99	76	-	200142

Performance curve at 2900 rpm

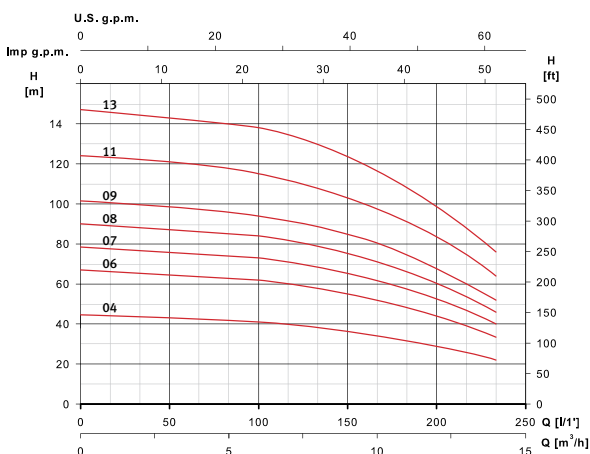

Dimension and weight

Model	Motor		Pump Multi VS		
	E1	E2	F1	F2	Kg
Multi VS 10 04	175	136	697	417	39
Multi VS 10 06	185	145	787	477	44
Multi VS 10 07	215	170	837	517	55
Multi VS 10 08	215	170	867	547	56
Multi VS 10 09	240	180	917	577	63
Multi VS 10 11	240	180	977	637	65
Multi VS 10 13	257	168	1165	775	86

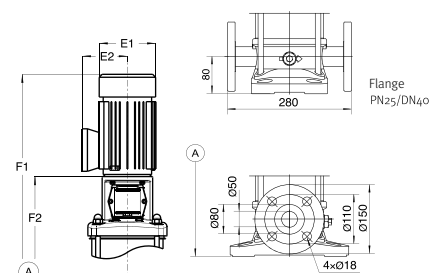

Multi VS 15 Supply | Vertical surface



Centrifugal multistage pump in-line for water supply, 100% stainless steel

Applications

Pumping of clean water for domestic, industrial, agricultural and gardening purposes.

Materials

Pump body, suction, discharge, diffusers and impellers in AISI 304.
Pump shaft in AISI 420.
Mechanical seal.
Motor casing in aluminum.
O-rings in FPM.

Equipment

No cable.
Counter flanges not included.
Motor-wet end coupling system
V18-flange C (IEC standard). For 11kW motor V1-flange FF (IEC standard).

Motor

Asynchronous 2 poles.
IPX4 protection.
Class F insulation.
Continuous operation.

Range of use

Maximum water temperature 120 °C.



100% stainless steel

Inline connection

Temperature up to 120°

Pressure up to 160 m

Flow rate up to 400 l/min

Features table

Model	Motor					Multi VS hydraulic data											Code		
	I [A]			P2		l/min													
	3~230V	3~400V	3~692V	[kW]	[HP]		0	200	233	250	267	300	333	367	400				
Multi VS 15 03	10	6,2	-	3	4	mwc	40	36	35	34	34	32	29	25	21	200145	-		
Multi VS 15 05	-	8,2	4,7	4	5,5		65	61	59	58	57	53	48	42	36	-	200146		
Multi VS 15 06	-	11,2	6,5	5,5	7,5		82	73	71	69	67	63	58	52	43	-	200147		
Multi VS 15 07	-	11,2	6,5	5,5	7,5		96	86	83	81	79	74	68	61	51	-	200148		
Multi VS 15 09	-	15,4	8,9	7,5	10		124	111	108	106	103	96	88	78	67	-	200149		
Multi VS 15 12	-	21,6	12,5	11	15		166	149	145	142	138	129	117	104	90	-	200150		

Performance curve at 2900 rpm

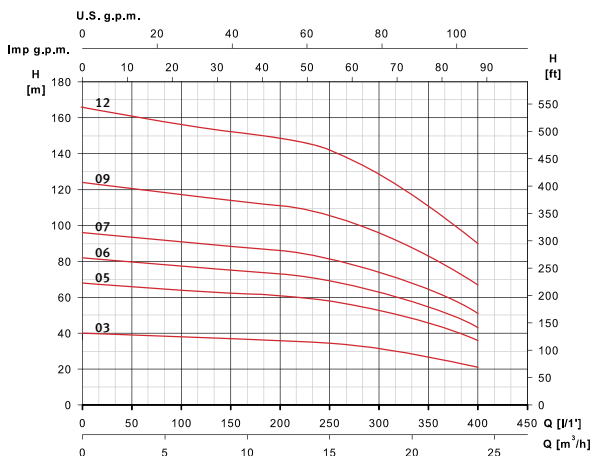

Dimension and weight

Model	Motor			Pump Multi VS		
	E1	E2	P	F1	F2	Kg
Multi VS 15 03	215	170	-	772	452	52
Multi VS 15 05	240	180	-	882	542	61
Multi VS 15 06	257	168	-	1055	665	83
Multi VS 15 07	257	168	-	1100	710	84
Multi VS 15 09	257	168	-	1190	800	92
Multi VS 15 12	314	261	300	1465	965	153

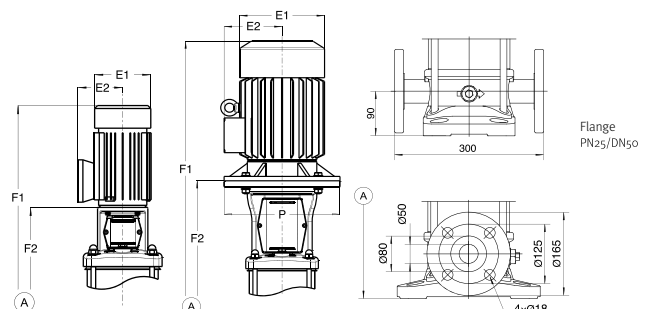

Multi VS 20 **Supply | Vertical surface**



Centrifugal multistage pump in-line for water supply, 100% stainless steel

Applications

Pumping of clean water for domestic, industrial, agricultural and gardening purposes.

Materials

Pump body, suction, discharge, diffusers and impellers in AISI 304.
Pump shaft in AISI 420.
Mechanical seal.
Motor casing in aluminum.
O-rings in FPM.

Equipment

No cable.
Counter flanges not included.
Motor-wet end coupling system V18-flange C (IEC standard). For 11kW and 15kW motor V1-flange FF (IEC standard).

Motor

Asynchronous 2 poles.
IPX4 protection.
Class F insulation.
Continuous operation.

Range of use

Maximum water temperature 120 °C.



100% stainless steel



Inline connection



Temperature up to 120°



Pressure up to 170 m



Flow rate up to 480 l/min

Features table

Model	Motor				Multi VS hydraulic data										Code
	I [A]		P2		l/min	0	267	300	333	367	400	433	467	483	
	3~400V	3~692V	[kW]	[HP]											
Multi VS 20 03	8,2	4,7	4	5,5	mwc	41	37	36	35	33	31	28	25	23	200152
Multi VS 20 05	11,2	6,5	5,5	7,5		69	62	60	58	55	51	47	42	40	200153
Multi VS 20 06	15,4	8,9	7,5	10		84	75	73	70	66	62	58	52	48	200154
Multi VS 20 08	21,6	12,5	11	15		113	101	98	95	90	84	77	70	66	200155
Multi VS 20 12	28,7	16,4	15	20		171	153	149	143	137	127	117	106	100	200156

Performance curve at 2900 rpm

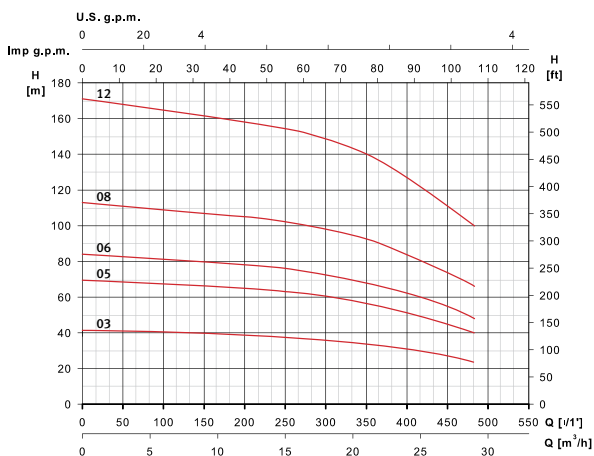

Dimension and weight

Model	Motor			Pump Multi VS		
	E1	E2	P	F1	F2	Kg
Multi VS 20 03	240	180	-	792	452	59
Multi VS 20 05	257	168	-	1010	620	83
Multi VS 20 06	257	168	-	1055	665	92
Multi VS 20 08	314	264	300	1285	785	160
Multi VS 20 12	314	261	350	1465	965	181

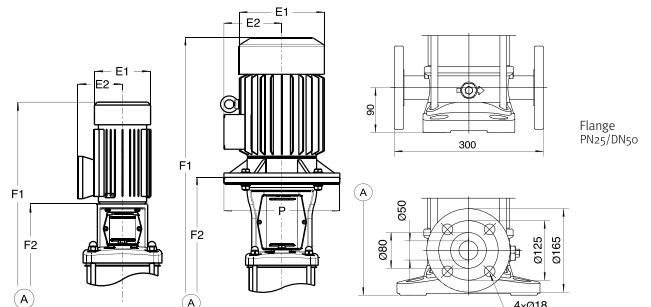



Supply
Automatic
pressurization

Automatic start and stop device

Applications

Assembled on a pump, automatic start and stop based on water demand.
Adjustable starting pressure Range of use from 1,5 to 2,5 bar.

Materials

Plastic components in technopolymer.
Internal membrane in EPDM.

Equipment

Built-in check valve.
Unions included.
Model NP with cables without plug.
Model 2E with cables and plug type F.
Dry-run protection.
Automatic reset function.



Dry running protection	Automatic reset	Start & stop according to water demand

Features table

Model	I [A] max.	Hz	Protection	Maximum pressure	Starting pressure	Differential pressure	Stopping pressure	Max. temp. [°C]	Ø Connection	Code	
										1~230V (Model NP)	1~230V (Model 2E)
Pressdrive	12	50/60	IP X5	10 bar	1,5 - 2,5 bar	≥ 0,7 bar	Max. given by the pump	40	1"	205333	205334

Dimension and weight

Model	A	B	Kg
Pressdrive	281	134	1,5

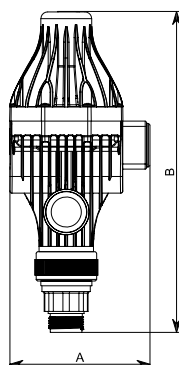

Automatic start and stop device

Applications

Assembled on a pump, automatic start and stop based on water demand.
Adjustable starting pressure Range of use from 1,5 to 2,5 bar.

Materials

Plastic components in technopolymer.
Internal membrane in EPDM.

Equipment

Built-in check valve.
Unions included.
Model NP with cables without plug.
Model 2E with cables and plug type F.
Dry-run protection.
Automatic reset function.



Dry running protection	Automatic reset	Start & stop according to water demand

Features table

Model	I [A] max.	Hz	Protection	Maximum pressure	Starting pressure	Differential pressure	Stopping pressure	Max. temp. [°C]	Ø Connection	Code	
										1~230V (Model NP)	1~230V (Model 2E)
Pressdrive 05	12	50/60	IP X5	10 bar	1,5 - 2,5 bar	≥ 1 bar	Max. given by the pump	40	1"	205331	205328

Dimension and weight

Model	A	B	C	D	E	Kg
Pressdrive 05	213	108	195	1"	155	1,5

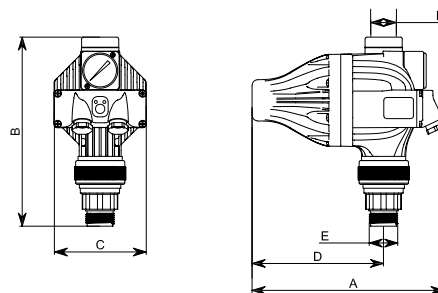

Variable frequency drive

Applications

Assembled on a pump, booster set or installed on the wall, adjust the speed automatically to maintain the constant pressure and flow that apartment, building or installation demands at every moment.



Materials

Body in aluminum.
Front cover in technopolymer.

Equipment and features

IPX5 protection.
Maximum ambient temperature 40 °C.
Air cooled motor.
Maximum 4 pumps.
USB port for updating the device's firmware.
Adjustable working frequency.
Inputs:
- 1 analogue 4-20mA with 24V DC power supply.
- 1 digital for the level switch.
Outputs:
- 1 alarm signal.
- Potential-free output (FVC), maximum 1A, NA/NC contacts.
Communication serial port RS 485.
M22 with 2m of cable with plug type F.
T22 and T55 no cable.



Pressure transducer*

Device for digital pressure reading

Protections

Dry-run protection with automatic reset.
Detection of pressure transducer failure.
Overcurrent and short-circuit with automatic reset.
Power supply voltage with automatic reset.
Internal overtemperature with automatic reset.
Earthing and motor phase error.
Communication error.

Features table

Model	Input				Output				Code
	Power source voltage [V]	Power frequency [Hz]	Maximum motor current [A]	Recommended line protection [A]	Maximum motor power [kW]	Maximum motor current [A]	Motor voltage [V]	Motor frequency [Hz]	
Speedrive V2 M22	1~ 220V	50/60	16	25	2,2	10	3~ 220V	50/60	203323
Speedrive V2 T22	3~ 440V	50/60	7	10	2,2	6	3~ 440V	50/60	205490
Speedrive V2 T55	3~ 440V	50/60	15	20	5,5	14	3~ 440V	50/60	203321

Accessories	Code
Pressure transducer 4- 20 mA 1/4 G 10 bar	176579
Wall installation kit	209380
PCBA Modbus circuit	214754

Dimension and weight

Model	A	B	C	D	Kg
Speedrive V2 M22	207	207	178	71	3,4
Speedrive V2 T22	207	207	142	85	2,7
Speedrive V2 T55	207	207	142	85	2,7

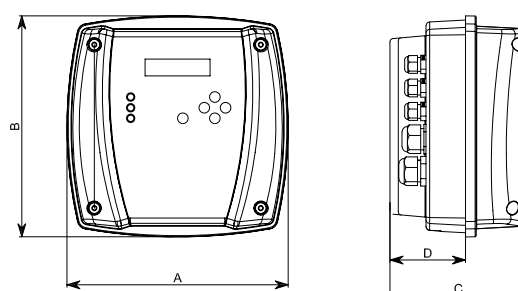

*Pressure transducer is required for operation.

Automatic set for water supply

Applications

Automatic pumping of clean water for domestic, industrial, agricultural and gardening purposes.
Silent.
Self-priming up to 2m.
Adjustable starting pressure Range of use from 1,5 to 2,5 bar.

Materials

Prisma:

Pump body and impellers in AISI 304.
Pump shaft in AISI 431.
Diffusers in technopolymer.
Suction and discharge in cast iron with cataphoresis coating.
Mechanical seal.
Motor casing in aluminum.

O-rings in NBR/EPDM.

Pressdrive:

Plastic components in technopolymer.
Internal membrane in EPDM.

Motor

Asynchronous 2 poles.
IPX5 protection.
Class F insulation.
Built-in thermal protection.
Continuous operation.

Range of use

Maximum water temperature 40 °C.

Equipment

Built-in check valve.
Unions included.
2m of cable with plug type F.
Dry-run protection.
Automatic reset function.

Operation

Automatic start and stop based on water demand.



Complete set	Plug&Play	Quiet	Start & stop according to water demand

Features table

Model	I [A]	P1 [kW]	P2		c [μF]	l/min	20	40	50	60	100	120	Code
	1~230V	1~	[kW]	[HP]									
PDS 3-50	2,7	0,61	0,37	0,5	12	mwc	30	22	17	11	-	-	199512
PDS 3-75	3,5	0,79	0,55	0,75	12		39	27	22	14	-	-	199513
PDS 3-100	4,1	0,95	0,75	1	12		47	34	25	17	-	-	199514
PDS 6-100	5,5	1,2	0,75	1	16		34	32	30	28	19	12	199515
PDS 6-125	6,8	1,5	0,9	1,2	16		44	42	40	37	24	15	199516

Performance curve at 2900 rpm

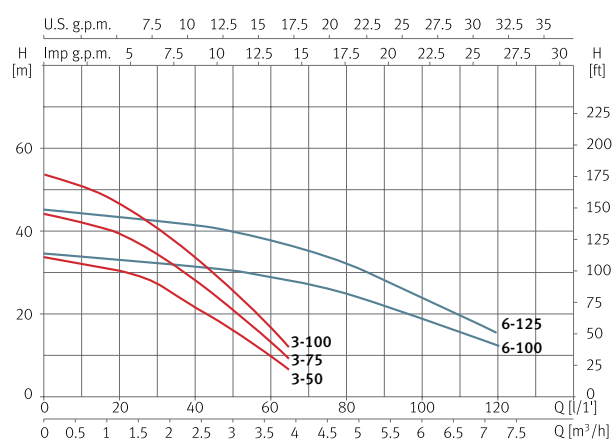

Dimension and weight

Model	A	B	C	D	E	Kg
PDS 3-50	390	431	1"	1"	102	11,2
PDS 3-75	413	431	1"	1"	102	11,7
PDS 3-100	437	431	1"	1"	102	12,7
PDS 6-100	420	529	1"	1"	118	15,2
PDS 6-125	447	529	1"	1"	118	16,3

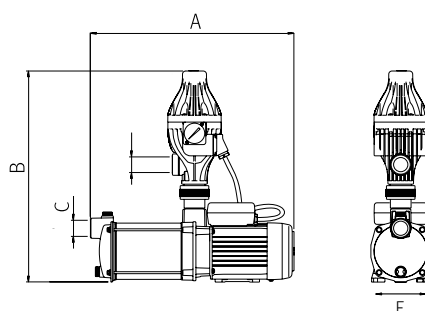

Automatic set for water supply

Applications

Automatic pumping of clean water for domestic, industrial, agricultural and gardening purposes.
 Silent.
 Self-priming up to 2m.
 Adjustable starting pressure Range of use from 1,5 to 2,5 bar.

Materials

Prisma:

Pump body and impellers in AISI 304.
 Pump shaft in AISI 431.
 Diffusers in technopolymer.
 Suction and discharge in cast iron with cataphoresis coating.
 Mechanical seal.
 Motor casing in aluminum.
 O-rings in NBR/EPDM.
Pressdrive 05:
 Plastic components in technopolymer.
 Internal membrane in EPDM.

Motor

Asynchronous 2 poles.
 IPX5 protection.
 Class F insulation.
 Built-in thermal protection.
 Continuous operation.

Range of use

Maximum water temperature 40 °C.

Equipment

Built-in check valve.
 Unions included.
 2m of cable with plug type F.
 Dry-run protection.
 Automatic reset function.

Operation

Automatic start and stop based on water demand.



Complete set	Plug&Play	Quiet	Start & stop according to water demand

Features table

Model	I [A]	P1 [kW]	P2		c [μF]	l/min	20	40	50	60	100	120	Code
	1~230V	1~	[kW]	[HP]			m³/h	1,2	2,4	3	3,6	6	
PDS 05 3-50	2,7	0,61	0,37	0,5	12	mwc	30	22	17	11	-	-	204702
PDS 05 3-75	3,5	0,79	0,55	0,75	12		39	27	22	14	-	-	204703
PDS 05 3-100	4,1	0,95	0,75	1	12		47	34	25	17	-	-	204704
PDS 05 6-100	5,5	1,2	0,75	1	16		34	32	30	28	19	12	204705
PDS 05 6-125	6,8	1,5	0,9	1,2	16		44	42	40	37	24	15	204706

Performance curve at 2900 rpm

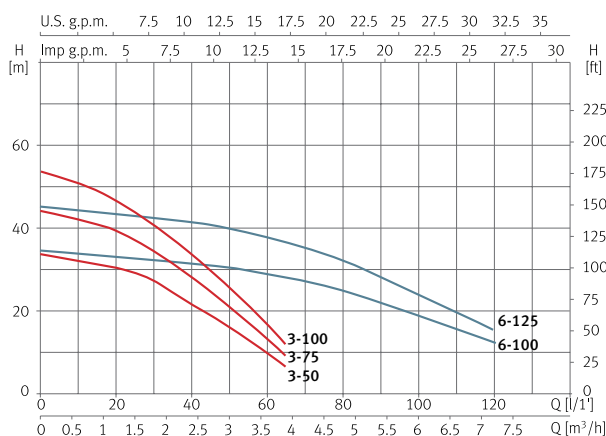

Dimension and weight

Model	A	B	C	D	E	Kg
PDS 05 3-50	390	345	1"	1"	102	10,8
PDS 05 3-75	413	345	1"	1"	102	11,3
PDS 05 3-100	437	345	1"	1"	102	12,3
PDS 05 6-100	420	443	1"	1"	108	14,8
PDS 05 6-125	447	443	1"	1"	108	15,9

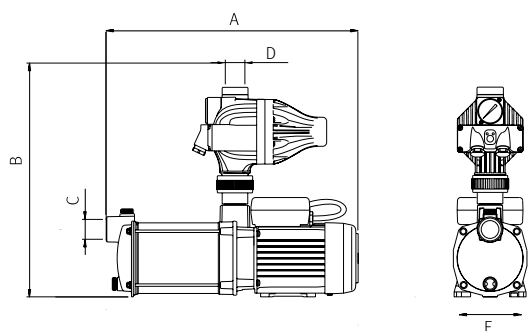

Automatic centrifugal multistage pump for water supply

Applications

Automatic pumping of clean water for domestic, industrial, agricultural and gardening purposes.
Silent.
Self-priming up to 2m.
Starting pressure 2 bar.

Materials

Pump body and impellers in AISI 304.
Pump shaft in AISI 431.
Diffusers in technopolymer.
Mechanical seal.
Motor casing in aluminum.
O-rings in NBR/EPDM.

Equipment

Built-in check valve.
2m of cable with plug type F.
Model KP with Kit Press included.
Dry-run protection.
Automatic reset function.

Motor

Asynchronous 2 poles.
IPX5 protection.
Class F insulation.
Built-in thermal protection.
Continuous operation.

Range of use

Maximum water temperature 40 °C.

Operation

Automatic start and stop based on water demand.



Features table

Model	I [A]	P1 [kW]	P2		c [μF]	l/min m³/h	15	30	45	60	75	90	105	120	Code
	1~230V	1~	[kW]	[HP]			0,9	1,8	2,7	3,6	4,5	5,4	6,3	7,2	
Tecnopres 15 4	3,5	0,79	0,55	0,75	12	mwc	40	35	24	14	-	-	-	-	97535
Tecnopres 15 5	4,1	0,95	0,75	1	12		48	42	29	17	-	-	-	-	97537
Tecnopres 25 4	6,8	1,5	0,9	1,2	16		43	42	40	37	33	28	22	15	97539
Tecnopres 25 5	7,4	1,7	1,1	1,5	30		56	55	53	48	43	37	29	20	97541

Performance curve at 2900 rpm

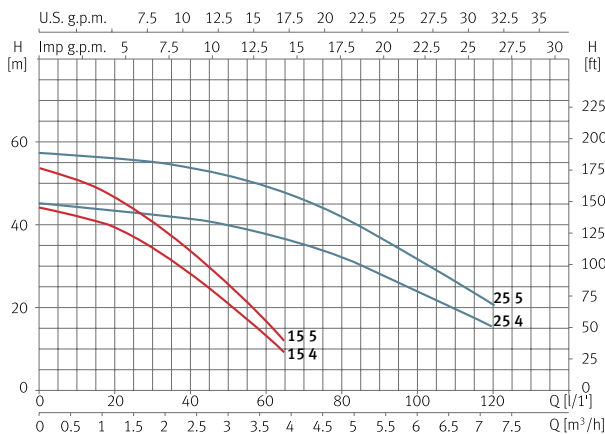

Dimension and weight

Model	A	B	C	D	E	F	G	H	DN	Kg
Tecnopres 15 4	88	149	196	108	281	188	221	233	1"	10,3
Tecnopres 15 5	88	149	196	108	305	188	244	233	1"	11,2
Tecnopres 25 4	88	149	196	108	298	188	237	267	1"	11,3
Tecnopres 25 5	88	149	196	108	325	188	263	289	1"	12,2

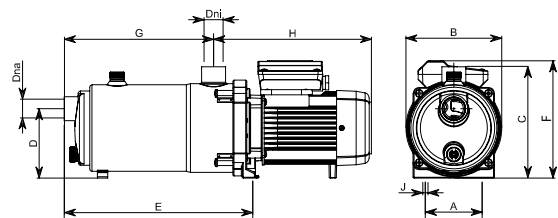

Automatic submersible monoblock centrifugal multistage pump for water supply

Applications

Automatic pumping of clean water for domestic, industrial, agricultural and gardening purposes.
Suitable for open wells, ponds and tanks.
Starting pressure 2 bar.

Materials

Pump body, suction, discharge, filter and impellers in AISI 304.
Pump shaft in AISI 431.
Diffusers in technopolymer.
Double mechanical seal.
O-rings in NBR/EPDM.

Equipment

Built-in check valve.
15m of cable without plug.
Internal capacitor.
Kit Press included.
Dry-run protection.
Automatic reset function.

Motor

Asynchronous 2 poles.
IPX8 protection.
Class F insulation.
Continuous operation.
Water cooled motor.
Built-in thermal protection.

Range of use

Maximum water temperature 40 °C.
Maximum submersion 12m.

Operation

Automatic start and stop based on water demand.



Complete set	Plug&Play	Submersible	Start & stop according to water demand

Features table

Model	I [A]	P1 [kW]	P2		c [μF]	l/min	10	20	30	40	50	60	65	Code
	1~230V	1~	[kW]	[HP]			m³/h	0,6	1,2	1,8	2,4	3,0	3,6	
Acuapres 07S 4	4	0,8	0,55	0,75	12	mwc	41	37	32	26	19	10	6	209179
Acuapres 07S 6	6,2	1,2	0,9	1,2	12		60	55	47	37	26	15	9	210154

Performance curve at 2900 rpm

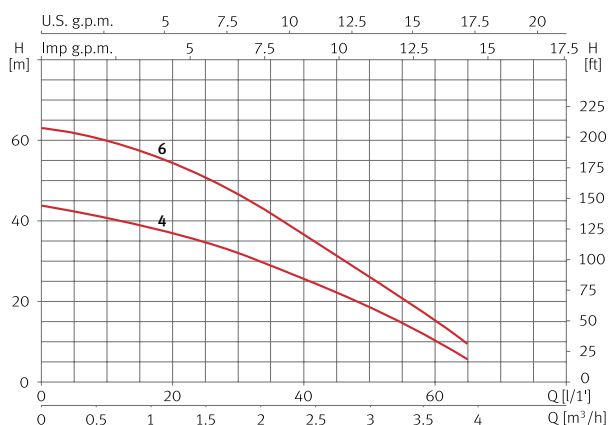

Dimension and weight

Model	A	B	C	Kg
Acuapres 07S 4	502	125	1"	10,6
Acuapres 07S 6	569	125	1"	12,4



Accessories	Code
5" top suction float kit	177113

Automatic centrifugal multistage pump with variable speed for water supply

Applications

Automatic pumping of clean water for domestic, industrial, agricultural and gardening purposes.
Silent.
Self-priming up to 2m.
Adjustable working pressure Range of use from 1,5 to 3,5 bar.

Materials

Pump body and impellers in AISI 304.
Pump shaft in AISI 431.
Diffusers in technopolymer.
Mechanical seal.
Motor casing in aluminum.
O-rings in NBR/EPDM.

Equipment

Built-in check valve.
Built-in pressure sensor.
2m of cable with plug type F.
Kit Press and pressure gauge included.
Dry-run protection.
Automatic reset function.

Motor

Asynchronous 2 poles.
IPX5 protection.
Class F insulation.
Built-in thermal protection.
Continuous operation.

Range of use

Maximum water temperature 40 °C.

Operation

Variable speed to maintain the constant pressure and flow that apartment, building or installation demand at every moment.



Complete set	Plug&Play	Ultra-quiet	Constant pressure	Maximum hydraulic comfort	Up to 5 taps simultaneously

Features table

Model	I [A]	P1 [kW]	P2		c [µF]	l/min	5	10	30	45	50	Code
	1~230V	1~	[kW]	[HP]		m³/h	0,3	0,6	1,8	2,7	3	
Tecnoplus 15 4	3,6	0,75	0,55	0,75	12	mwc	36	36	30	21	16,5	131059

Performance curve

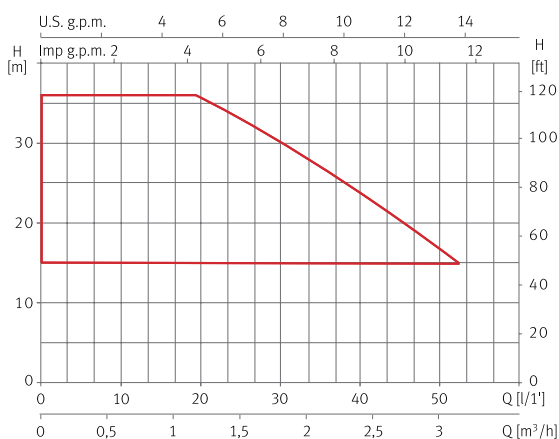

Dimension and weight

Model	A	B	C	D	E	F	G	H	J	K	L	M	Kg
Tecnoplus 15 4	439	108	261	200	216	241	254	88	Ø243	196	1"	1"	10,5

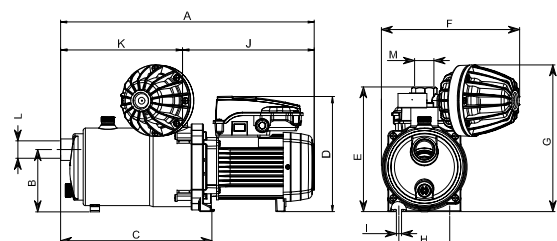

Tecnoplus 25 **Supply | Booster**



Automatic centrifugal multistage pump with variable speed for water supply

Applications

Automatic pumping of clean water for domestic, industrial, agricultural and gardening purposes.
Silent.
Self-priming up to 2m.
Adjustable working pressure Range of use from 1,5 to 4 bar.

Materials

Pump body and impellers in AISI 304.
Pump shaft in AISI 431.
Diffusers in technopolymer.
Mechanical seal.
Motor casing in aluminum.
O-rings in NBR/EPDM.

Equipment

Built-in check valve.
Built-in pressure sensor.
2m of cable with plug type F.
Kit Press and pressure gauge included.
Dry-run protection.
Automatic reset function.

Motor

Asynchronous 2 poles.
IPX5 protection.
Class F insulation.
Built-in thermal protection.
Continuous operation.

Range of use

Maximum water temperature 40 °C.

Operation

Variable speed to maintain the constant pressure and flow that apartment, building or installation demands at every moment.



Complete set	Plug&Play	Ultra-quiet	Constant pressure	Maximum hydraulic comfort	Up to 12 taps simultaneously

Features table

Model	I [A]	P1 [kW]	P2		l/min	45	60	75	90	110	Code
	1~230V	1~	[kW]	[HP]	m³/h	2,7	3,6	4,5	5,4	6,6	1~230V
Tecnoplus 25 4	8,8	1,4	0,9	1,2	mwc	40	37	33	25	19	167577

Performance curve

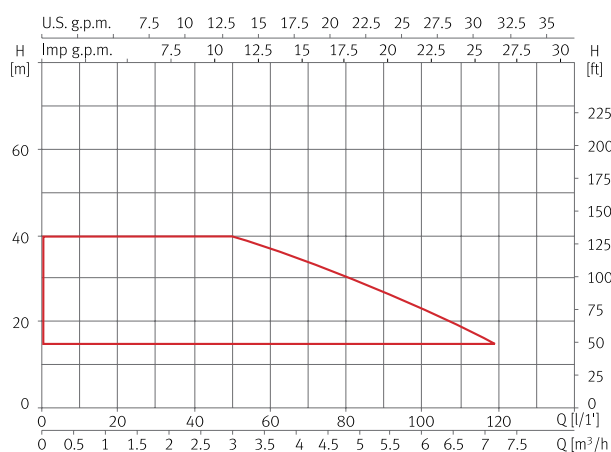

Dimension and weight

Model	A	B	C	D	E	F	G	H	I	J	K	L	Kg
Tecnoplus 25 4	468	107	244	221	216	149	254	88	190	Ø9	278	1"	15,5

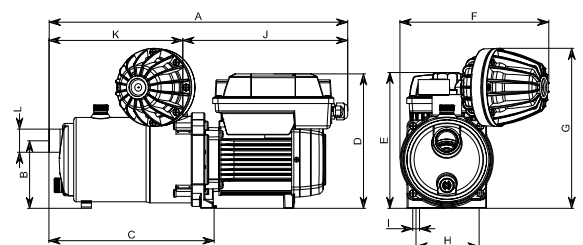

Automatic booster set with single speed for water supply

Applications

Automatic pumping of clean water for domestic, industrial, agricultural and gardening purposes.
Fixed speed working pressure.

Materials

Multi:

Pump body and impellers in AISI 304.
Pump shaft in AISI 420.
Diffusers in technopolymer.
Suction and discharge in cast iron with cataphoresis coating.
Mechanical seal.
Motor casing in aluminum.
O-rings in NBR/EPDM.
Manifolds: AISI 304.
Valves and fittings: Brass.

Equipment included

Control drive.
Discharge manifold.
Control panel.
Valves.
Fittings.
Check valves.
Pressure transducer.
Metallic base.

Motor

Asynchronous 2 poles.
IPX5 protection.
Class F insulation.
Continuous operation.

Range of use

Maximum water temperature 40 °C.

Functions and protections

Pressure transducer failure.
Overcurrent and short-circuit with automatic reset.

Operation

Automatic start and stop based on water demand. The set works in fixed speed.



CPE 1



CPE 2

Features table, dimension and weight

Model	Nº pumps	P2 [kW]	Ø Pump		Ø Discharge manifold	Dimensions			Weight [Kg]	Tank recommended*	Code	
			Suction	Discharge		length	width	height			1-230V	3-400V
CPE 1 MULTI 25 4	1	0,75	1 1/4"	1 1/4"	2"	400	450	600	30	150 l	177638	177622
CPE 1 MULTI 25 5	1	0,9	1 1/4"	1 1/4"	2"	400	450	600	30	150 l	177639	177624
CPE 1 MULTI 35 4	1	1,1	1 1/2"	1 1/4"	2"	400	500	650	40	200 l	177640	177626
CPE 1 MULTI 35 5	1	1,5	1 1/2"	1 1/4"	2"	400	500	650	41	200 l	177641	177628
CPE 1 MULTI 35 6	1	2,2	1 1/2"	1 1/4"	2"	400	500	650	42	300 l	-	177630
CPE 1 MULTI 35 8	1	3	1 1/2"	1 1/4"	2"	400	500	650	45	300 l	-	177631
CPE 1 MULTI 55 4	1	2,2	1 1/2"	1 1/4"	3"	400	550	700	45	500 l	-	177635
CPE 1 MULTI 55 6	1	3	1 1/2"	1 1/4"	3"	400	550	700	50	500 l	-	177636
CPE 1 MULTI 55 7	1	4	1 1/2"	1 1/4"	3"	400	550	700	55	700 l	-	177637
CPE 2 MULTI 25 4	2	0,75	1 1/4"	1 1/4"	2"	640	360	850	50	150 l	177290	177289
CPE 2 MULTI 25 5	2	0,9	1 1/4"	1 1/4"	2"	640	360	850	50	150 l	177293	177292
CPE 2 MULTI 35 4	2	1,1	1 1/2"	1 1/4"	2"	640	395	855	60	200 l	177296	177295
CPE 2 MULTI 35 5	2	1,5	1 1/2"	1 1/4"	2"	640	395	865	65	200 l	177299	177298
CPE 2 MULTI 35 6	2	2,2	1 1/2"	1 1/4"	2"	640	395	905	66	300 l	-	177301
CPE 2 MULTI 35 8	2	3	1 1/2"	1 1/4"	2"	640	423	955	80	300 l	-	177302
CPE 2 MULTI 55 4	2	2,2	1 1/2"	1 1/4"	3"	640	423	960	73	500 l	-	177307
CPE 2 MULTI 55 6	2	3	1 1/2"	1 1/4"	3"	640	430	1040	90	500 l	-	177308
CPE 2 MULTI 55 7	2	4	1 1/2"	1 1/4"	3"	640	430	1085	99	700 l	-	177309

Model	Ø Manifold	Ø Valves	Ø Flanges	Code
Suction kit for CPE 2 Multi 25	2"	1 1/4"	1 1/4"	199701
Suction kit for CPE 2 Multi 35	2"	1 1/2"	1 1/2"	199702
Suction kit for CPE 2 Multi 55	3"	1 1/2"	1 1/2"	199703

* The tank is not included.

Automatic booster set with variable speed for water supply

Applications

Automatic pumping of clean water for domestic, industrial, agricultural and gardening purposes.
Adjustable working pressure.

Materials

Multi:

Pump body and impellers in AISI 304.
Pump shaft in AISI 420.
Diffusers in technopolymer.
Suction and discharge in cast iron with cataphoresis coating.
Mechanical seal.
Motor casing in aluminum.
O-rings in NBR/EPDM.
Manifolds: AISI 304.
Valves and fittings: Brass.

Equipment included

Pump.
Speedrive V2.
Discharge manifold.
Control panel.
Valves.
Fittings.
Check valves.
Pressure tank (20l).
Pressure transducer.
Metallic base.

Motor

Asynchronous 2 poles.
IPX5 protection.
Class F insulation.
Continuous operation.

Range of use

Maximum water temperature 40 °C.

Functions and protections

Dry-run protection with automatic reset function.
Detection of pressure transducer failure.
Overcurrent and short-circuit with automatic reset.
Power supply voltage with automatic reset.
Internal overtemperature with automatic reset.
Earthing and motor phase error.
Communication error.

Operation

Variable speed to maintain the constant pressure and flow that apartment, building or installation demands at every moment.



Complete set	Plug&Play	Ultra-quiet	Constant pressure	Maximum hydraulic comfort	Residential, commercial and agricultural use

Features table

Model	Maximum head [m]	Maximum flow [m³/h]	P2 [kW]	Speedrive V2	Ø Pump		Ø Discharge manifold	Code	
					Suction	Discharge		1~230V	3~400V
CKE 1 Multi 25 4	59	5	0,75	M22/T22	1 1/4"	1 1/4"	2"	176824	176450
CKE 1 Multi 25 5	74	5	0,9	M22/T22	1 1/4"	1 1/4"	2"	176826	176825
CKE 1 Multi 35 4	55	10,5	1,1	M22/T22	1 1/2"	1 1/4"	2"	176828	176827
CKE 1 Multi 35 5	67	10,5	1,5	M22/T22	1 1/2"	1 1/4"	2"	176830	176829
CKE 1 Multi 35 6	83	10,5	2,2	M22/T22	1 1/2"	1 1/4"	2"	205264	176831
CKE 1 Multi 35 8	110	10,5	3	T55	1 1/2"	1 1/4"	2"	-	176832
CKE 1 Multi 55 4	51	18	2,2	T22	1 1/2"	1 1/4"	2"	-	176835
CKE 1 Multi 55 6	79	18	3	T55	1 1/2"	1 1/4"	2"	-	176836
CKE 1 Multi 55 7	93	18	4	T55	1 1/2"	1 1/4"	2"	-	176837

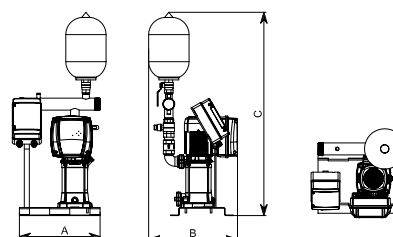

Dimension and weight

Model	A	B	C	Kg
CKE 1 Multi 25	400	450	1150	40
CKE 1 Multi 35	400	500	1200	50/55
CKE 1 Multi 55	400	550	1250	55/60

Automatic booster set with variable speed for water supply

Applications

Automatic pumping of clean water for domestic, industrial, agricultural and gardening purposes.
Adjustable working pressure.

Materials

Pump body and impellers in AISI 304.
Pump shaft in AISI 420.
Diffusers in technopolymer.
Suction and discharge in cast iron with cathoporesis coating.
Mechanical seal.
Motor casing in aluminum.
O-rings in NBR/EPDM.
Manifolds: AISI 304.
Valves and fittings: Brass.

Equipment included

Pump (x2).
Speeddrive V2 (x2).
Discharge and suction manifold.
Control panel.
Valves.
Fittings.
Check valves.
Pressure tank (20l).
Pressure transducer.
Metallic base.

Motor

Asynchronous 2 poles.
IPX5 protection.
Class F insulation.
Continuous operation.

Range of use

Maximum water temperature 40 °C.

Functions and protections

Dry-run protection with automatic reset function.
Detection of pressure transducer failure.
Overcurrent and short-circuit with automatic reset.
Power supply voltage with automatic reset.
Internal overtemperature with automatic reset.
Earthing and motor phase error.
Communication error.

Operation

Variable speed to maintain the constant pressure and flow that apartment, building or installation demands at every moment.



Complete set	Plug&Play	Ultra-quiet	Constant pressure	Maximum hydraulic comfort	Residential, commercial and agricultural use

Features table

Model	Maximum head[m]	Maximum flow [m³/h]	P2 [kW]	Speeddrive V2	Ø Pump		Ø Suction manifold	Ø Discharge manifold	Code	
					Suction	Discharge			1~230V	3~400V
CKE 2 Prisma 35 6	85	18	2,2	M22/T22	1 1/4"	1 1/4"	2"	2"	216672	216673

Performance curve

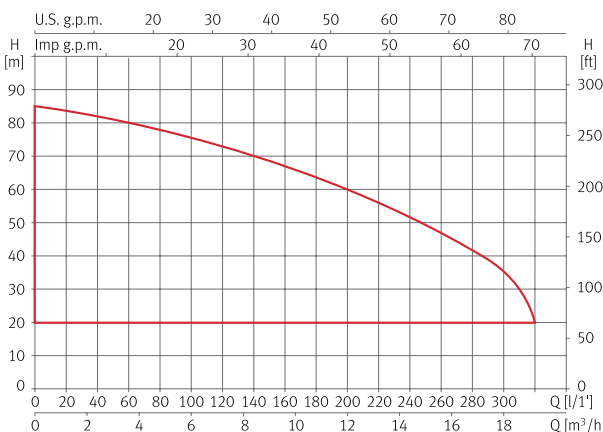

Dimension and weight

Model	A	B	C	Kg
CKE 2 Prisma 35 6	635	755	1047	80

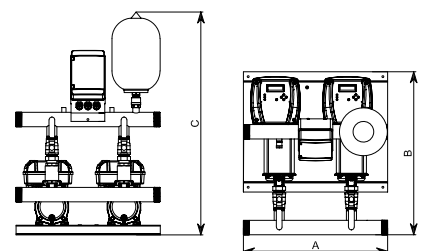

Automatic booster set with variable speed for water supply

Applications

Automatic pumping of clean water for domestic, industrial, agricultural and gardening purposes.
Adjustable working pressure.

Materials

Multi and VE:

Pump body and impellers in AISI 304.
Pump shaft in AISI 420.
Diffusers in technopolymer.
Suction and discharge in cast iron with cataphoresis coating.
Mechanical seal.
Motor casing in aluminum.
O-rings in NBR/EPDM.

Multi VS:

Pump body, suction, discharge, diffusers and impellers in AISI 304.
Mechanical seal.
Motor casing in aluminum.
O-rings in FPM.

Manifolds: AISI 304.

Valves and fittings: Brass.

Motor

Asynchronous 2 poles.
IPX5 protection.
Class F insulation.
Continuous operation.

Range of use

Maximum water temperature:
CKE with Multi and VE 40 °C.
CKE with Multi VS 120 °C.

Functions and protections

Dry-run protection with automatic reset function.
Detection of pressure transducer failure.
Overcurrent and short-circuit with automatic reset.
Power supply voltage with automatic reset.
Internal overtemperature with automatic reset.
Earthing and motor phase error.
Communication error.

Operation

Variable speed to maintain the constant pressure and flow that apartment, building or installation demands at every moment.



Equipment included

Pump (x2).
Speedrive V2 (x2).
Discharge manifold.
Model ASP with suction manifold.
Control panel.
Valves.
Fittings.
Check valves.
Pressure tank (20l).
Pressure transducer.
Metallic base.

Complete set	Plug&Play	Ultra-quiet
Constant pressure	Maximum hydraulic comfort	Residential, commercial and agricultural use



CKE 2 Multi

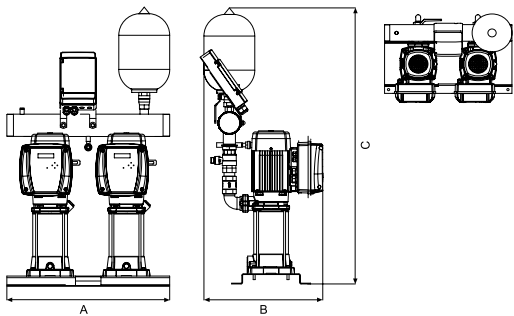

CKE 2 Multi VE

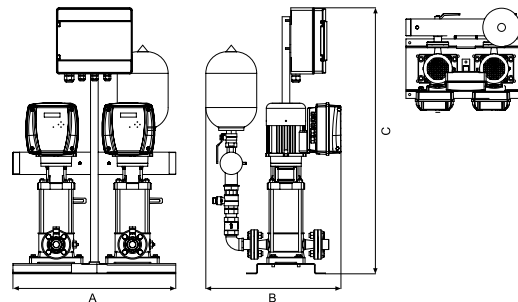

Features table, dimension and weight

Model	Maximum head [m]	Maximum flow [m³/h]	P2 [kW]	Speeddrive V2	Ø Pump		Ø Manifold	Dimensions			Weight [Kg]	Code	
					Suc.	Dis.		A	B	C		1~230V	1~230V (Model ASP)
CKE 2M Multi 25 4	59	10	0,75	M22	1 1/4"	1 1/4"	2"	640	440	975	56	176761	180440
CKE 2M Multi 25 5	74	10	0,92	M22	1 1/4"	1 1/4"	2"	640	440	994	57	176762	180441
CKE 2M Multi 35 4	55	21	1,1	M22	1 1/2"	1 1/4"	2"	640	464	1022	66	176763	180454
CKE 2M Multi 35 5	67	21	1,5	M22	1 1/2"	1 1/4"	2"	640	464	1045	72	176764	180455
CKE 2M Multi 35 6	83	21	2,2	M22	1 1/2"	1 1/4"	2"	640	464	1071	73	205266	216585

Model	Maximum head [m]	Maximum flow [m³/h]	P2 [kW]	Speeddrive V2	Ø Pump		Ø Manifold	Dimensions			Weight [Kg]	Code	
					Suc.	Dis.		A	B	C		3~400V	3~400V (Model ASP)
CKE 2 Multi 25 4	59	10	0,75	T22	1 1/4"	1 1/4"	2"	640	440	975	56	176452	180438
CKE 2 Multi 25 5	74	10	0,92	T22	1 1/4"	1 1/4"	2"	640	440	994	57	176744	180439
CKE 2 Multi 35 4	55	21	1,1	T22	1 1/2"	1 1/4"	2"	640	464	1022	66	176753	180456
CKE 2 Multi 35 5	67	21	1,5	T22	1 1/2"	1 1/4"	2"	640	464	1045	72	176754	180457
CKE 2 Multi 35 6	83	21	2,2	T22	1 1/2"	1 1/4"	2"	640	464	1071	73	176755	180458
CKE 2 Multi 35 8	110	21	3	T55	1 1/2"	1 1/4"	2"	640	500	1120	87	176756	180459
CKE 2 Multi 35 10	138	21	4	T55	1 1/2"	1 1/4"	2"	640	500	1170	106	176757	202401
CKE 2 Multi 55 4	51	36	2,2	T22	1 1/2"	1 1/4"	3"	640	500	1127	79	176758	180501
CKE 2 Multi 55 6	79	36	3	T55	1 1/2"	1 1/4"	3"	640	533	1206	97	176759	180502
CKE 2 Multi 55 7	93	36	4	T55	1 1/2"	1 1/4"	3"	640	533	1250	106	176760	180503

Model	Ø Manifold	Ø Valves	Ø Flanges	Code
Suction kit for CKE 2 Multi 25	2"	1 1/4"	1 1/4"	199701
Suction kit for CKE 2 Multi 35	2"	1 1/2"	1 1/2"	199702
Suction kit for CKE 2 Multi 55	3"	1 1/2"	1 1/2"	199703

Model	Maximum head [m]	Maximum flow [m³/h]	P2 [kW]	Speeddrive V2	Ø Pump Suc. / Dis.		Ø Manifold	Dimensions			Weight [Kg]	Code	
					A	B		C	3~400V	3~400V (Model ASP)			
CKE 2 VE 121 3	50	54,5	4	T55	50	50	4"	650	550	1147	156	203940	209330
CKE 2 VE 121 5	83	54,5	5,5	T55	50	50	4"	650	550	1295	200	203941	208675

Model	Ø Manifold	Ø Valves	Ø Flanges	Code
Suction kit for CKE 2 VE 121 3	4"	2"	2"	213982
Suction kit for CKE 2 VE 121 5	4"	2"	2"	186696

CKE 2 Multi VS

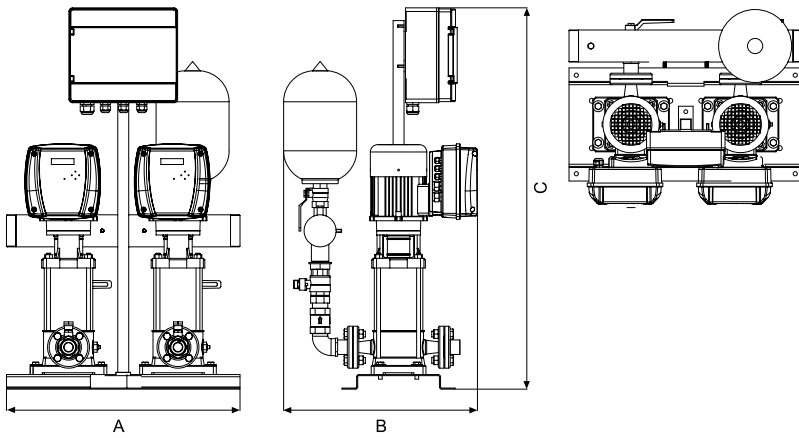

Features table, dimension and weight

Model	Maximum head [m]	Maximum flow [m³/h]	P2 [kW]	Speedrive V2	Ø Pump Suc. / Dis.	Ø Manifold	Dimensions			Weight [Kg]	Code	
							A	B	C		1~230V	1~230V (Model ASP)
CKE 2M Multi VS 05 06	45	15	1,1	M22	25	2"	650	550	915	75	203997	205820
CKE 2M Multi VS 05 09	65	15	1,5	M22	25	2"	650	550	950	80	203998	205821
CKE 2M Multi VS 05 10	75	15	1,5	M22	25	2"	650	550	1000	90	203999	205822
CKE 2M Multi VS 10 04	45	24	1,5	M22	25	3"	650	550	950	80	204001	205824

Model	Maximum head [m]	Maximum flow [m³/h]	P2 [kW]	Speedrive V2	Ø Pump Suc. / Dis.	Ø Manifold	Dimensions			Weight [Kg]	Code	
							A	B	C		3~400V	3~400V (Model ASP)
CKE 2 Multi VS 05 06	45	15	1,1	T22	25	2"	650	550	915	75	204007	205830
CKE 2 Multi VS 05 09	65	15	1,5	T22	25	2"	650	550	950	80	204008	205831
CKE 2 Multi VS 05 10	75	15	1,5	T22	25	2"	650	550	1000	90	204009	205832
CKE 2 Multi VS 05 11	80	15	1,5	T22	25	2"	650	550	1100	95	204010	205833
CKE 2 Multi VS 05 12	90	15	2,2	T22	25	2"	650	550	1200	100	204011	205834
CKE 2 Multi VS 05 14	105	15	2,2	T22	25	2"	650	550	1300	120	204012	205835
CKE 2 Multi VS 05 18	135	15	3	T55	25	2"	650	550	1600	150	204013	205836
CKE 2 Multi VS 10 04	45	24	1,5	T22	25	3"	650	550	950	100	204015	205838
CKE 2 Multi VS 10 06	65	24	2,2	T22	25	3"	650	550	1000	110	204016	205839
CKE 2 Multi VS 10 07	75	24	3	T55	25	3"	650	550	1050	120	204017	205840
CKE 2 Multi VS 10 08	90	24	3	T55	25	3"	650	550	1100	130	203976	205841
CKE 2 Multi VS 10 09	100	24	4	T55	25	3"	650	550	1150	140	204019	205842
CKE 2 Multi VS 10 11	120	24	4	T55	25	3"	650	550	1200	150	204020	205843
CKE 2 Multi VS 10 13	145	24	5,5	T55	25	3"	650	550	1200	160	216845	216846
CKE 2 Multi VS 15 03	40	42	3	T55	50	4"	650	550	1050	140	204024	205845
CKE 2 Multi VS 15 05	70	42	4	T55	50	4"	650	550	1100	150	204025	205846
CKE 2 Multi VS 15 06	80	42	5,5	T55	50	4"	650	550	1150	160	204026	205847
CKE 2 Multi VS 15 07	95	42	5,5	T55	50	4"	650	550	1150	170	216847	216848
CKE 2 Multi VS 20 03	40	54	4	T55	50	5"	650	550	700	200	204031	205849
CKE 2 Multi VS 20 05	70	54	5,5	T55	50	5"	650	550	750	210	204032	205850

Automatic booster set with variable speed for water supply

Applications

Automatic pumping of clean water for domestic, industrial, agricultural and gardening purposes.
Adjustable working pressure.

Materials

Multi and VE:

Pump body and impellers in AISI 304.
Pump shaft in AISI 420.
Diffusers in technopolymer.
Suction and discharge in cast iron with cathaphoresis coating.
Mechanical seal.
Motor casing in aluminum.
O-rings in NBR/EPDM.

Multi VS:

Pump body, suction, discharge, diffusers and impellers in AISI 304.
Mechanical seal.
Motor casing in aluminum.
O-rings in FPM.

Manifolds: AISI 304.

Valves and fittings: Brass.

Motor

Asynchronous 2 poles.
IPX5 protection.
Class F insulation.
Continuous operation.

Range of use

Maximum water temperature:
CKE with Multi and VE 40 °C.
CKE with Multi VS 120 °C.

Functions and protections

Dry-run protection with automatic reset function.
Detection of pressure transducer failure.
Overcurrent and short-circuit with automatic reset.
Power supply voltage with automatic reset.
Internal overtemperature with automatic reset.
Earthing and motor phase error.
Communication error.

Operation

Variable speed to maintain the constant pressure and flow that apartment, building or installation demands at every moment.



Equipment included

Pump (x3).
Speedrive V2 (x3).
Discharge manifold.
Model ASP with suction manifold.
Control panel.
Valves.
Fittings.
Check valves.
Pressure tank (20l).
Pressure transducer.
Metallic base.

Complete set	Plug&Play	Ultra-quiet
Constant pressure	Maximum hydraulic comfort	Residential, commercial and agricultural use



CKE 3 Multi

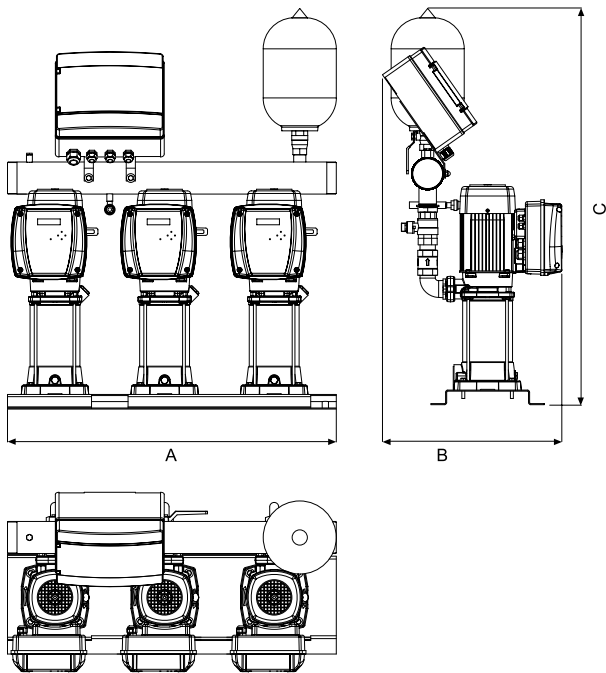

CKE 3 Multi VE

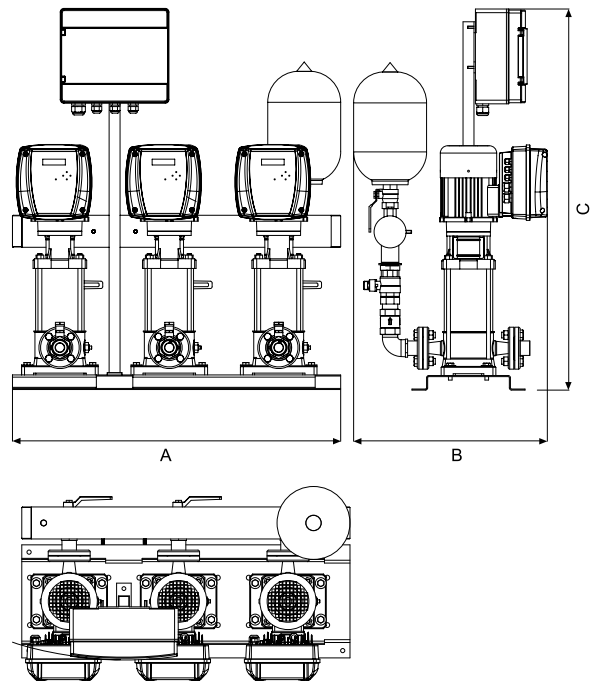

Features table, dimension and weight

Model	Maximum head [m]	Maximum flow [m³/h]	P2 [kW]	Speedrive V2	Ø Pump		Ø Manifold	Dimensions			Weight [Kg]	Code	
					Suc.	Dis.		A	B	C		3~400V	3~400V (Model ASP)
CKE 3 Multi 35 4	55	31,5	1,1	T22	1 1/2"	1 1/4"	3"	900	464	1044	99	176742	180475
CKE 3 Multi 35 5	67	31,5	1,5	T22	1 1/2"	1 1/4"	3"	900	464	1067	107	176743	180476
CKE 3 Multi 35 6	83	31,5	2,2	T22	1 1/2"	1 1/4"	3"	900	464	1093	109	176453	180477
CKE 3 Multi 35 8	110	31,5	3	T55	1 1/2"	1 1/4"	3"	900	500	1142	130	176745	180478
CKE 3 Multi 35 10	138	31,5	4	T55	1 1/2"	1 1/4"	3"	900	500	1170	151	176746	180479
CKE 3 Multi 55 4	51	54	2,2	T22	1 1/2"	1 1/4"	3"	900	500	1149	118	176748	180516
CKE 3 Multi 55 6	79	54	3	T55	1 1/2"	1 1/4"	3"	900	533	1228	144	176749	180518
CKE 3 Multi 55 7	93	54	4	T55	1 1/2"	1 1/4"	3"	900	533	1272	157	176750	180519

Model	Ø Manifold	Ø Valves	Ø Flanges	Code
Suction kit for CKE 3 Multi 35 and Multi 55	3"	1 1/2"	1 1/2"	205223

Model	Maximum head [m]	Maximum flow [m³/h]	P2 [kW]	Speedrive V2	Ø Pump Suc. / Dis.		Ø Manifold	Dimensions			Weight [Kg]	Code	
					Suc.	Dis.		A	B	C		3~400V	3~400V (Model ASP)
CKE 3 VE 121 3	50	82	4	T55	50	50	4"	900	550	1147	234	203945	216586
CKE 3 VE 121 5	83	82	5,5	T55	50	50	4"	900	550	1295	300	203946	206668

Model	Ø Manifold	Ø Valves	Ø Flanges	Code
Suction kit for CKE 3 VE 121 3	4"	2"	2"	213984
Suction kit for CKE 3 VE 121 5	4"	2"	2"	178038

CKE 3 Multi VS

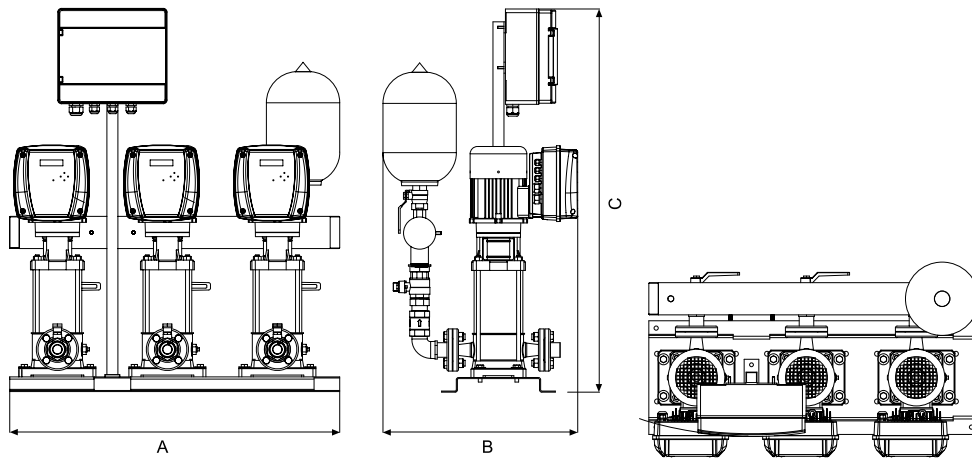

Features table, dimension and weight

Model	Maximum head [m]	Maximum flow [m ³ /h]	P2 [kW]	Speedrive V2	Ø Pump Suc. / Dis.	Ø Manifold	Dimensions			Weight [kg]	Code	
							A	B	C		3-400V	3-400V (Model ASP)
CKE 3 Multi VS 05 06	45	22,5	1,1	T22	25	2"	900	550	915	125	204041	205856
CKE 3 Multi VS 05 09	65	22,5	1,5	T22	25	2"	900	550	950	130	204042	205857
CKE 3 Multi VS 05 10	75	22,5	1,5	T22	25	2"	900	550	1000	140	204043	205858
CKE 3 Multi VS 05 11	80	22,5	1,5	T22	25	2"	900	550	1100	145	204044	205859
CKE 3 Multi VS 05 12	90	22,5	2,2	T22	25	2"	900	550	1200	150	204045	205860
CKE 3 Multi VS 05 14	105	22,5	2,2	T22	25	2"	900	550	1300	170	204046	205861
CKE 3 Multi VS 05 18	135	22,5	3	T55	25	2"	900	550	1600	200	204047	205862
CKE 3 Multi VS 10 04	45	36	1,5	T22	25	3"	900	550	950	150	204049	205864
CKE 3 Multi VS 10 06	65	36	2,2	T22	25	3"	900	550	1000	160	204050	205865
CKE 3 Multi VS 10 07	75	36	3	T55	25	3"	900	550	1050	170	204051	205868
CKE 3 Multi VS 10 08	90	36	3	T55	25	3"	900	550	1100	180	204018	205867
CKE 3 Multi VS 10 09	100	36	4	T55	25	3"	900	550	1150	190	204053	205868
CKE 3 Multi VS 10 11	120	36	4	T55	25	3"	900	550	1200	200	204054	205869
CKE 3 Multi VS 10 13	145	36	5,5	T55	25	3"	900	550	1200	210	216849	216850
CKE 3 Multi VS 15 03	40	63	3	T55	50	4"	900	550	1050	190	204058	205871
CKE 3 Multi VS 15 05	70	63	4	T55	50	4"	900	550	1100	200	204059	205872
CKE 3 Multi VS 15 06	80	63	5,5	T55	50	4"	900	550	1150	210	204060	205873
CKE 3 Multi VS 15 07	95	36	5,5	T55	50	4"	900	550	1150	220	216851	216852
CKE 3 Multi VS 20 03	40	81	4	T55	50	5"	900	550	700	250	204065	205875
CKE 3 Multi VS 20 05	70	81	5,5	T55	50	5"	900	550	750	260	204066	205876

Automatic booster set with variable speed for water supply

Applications

Automatic pumping of clean water for domestic, industrial, agricultural and gardening purposes.
Adjustable working pressure.

Materials

Multi and VE:

Pump body and impellers in AISI 304.
Pump shaft in AISI 420.
Diffusers in technopolymer.
Suction and discharge in cast iron with cataphoresis coating.
Mechanical seal.
Motor casing in aluminum.
O-rings in NBR/EPDM.

Multi VS:

Pump body, suction, discharge, diffusers and impellers in AISI 304.
Mechanical seal.
Motor casing in aluminum.
O-rings in FPM.

Manifolds: AISI 304.

Valves and fittings: Brass.

Motor

Asynchronous 2 poles.
IPX5 protection.
Class F insulation.
Continuous operation.

Range of use

Maximum water temperature:
CKE with Multi and VE 40 °C.
CKE with Multi VS 120 °C.

Functions and protections

Dry-run protection with automatic reset function.
Detection of pressure transducer failure.
Overcurrent and short-circuit with automatic reset.
Power supply voltage with automatic reset.
Internal overtemperature with automatic reset.
Earthing and motor phase error.
Communication error.

Operation

Variable speed to maintain the constant pressure and flow that apartment, building or installation demands at every moment.



Equipment included

Pump (x4).
Speedrive V2 (x4).
Discharge manifold.
Model ASP with suction manifold.
Control panel.
Valves.
Fittings.
Check valves.
Pressure tank (20l).
Pressure transducer.
Metallic base.



CKE 4 Multi

CKE 4 Multi VE

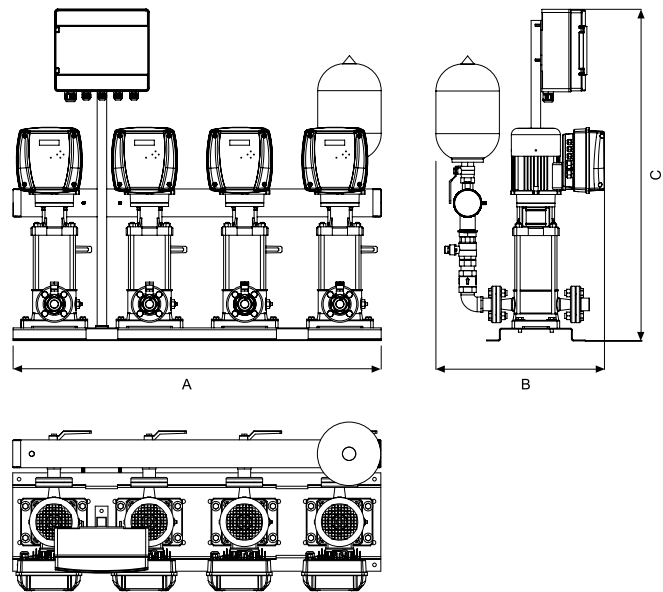
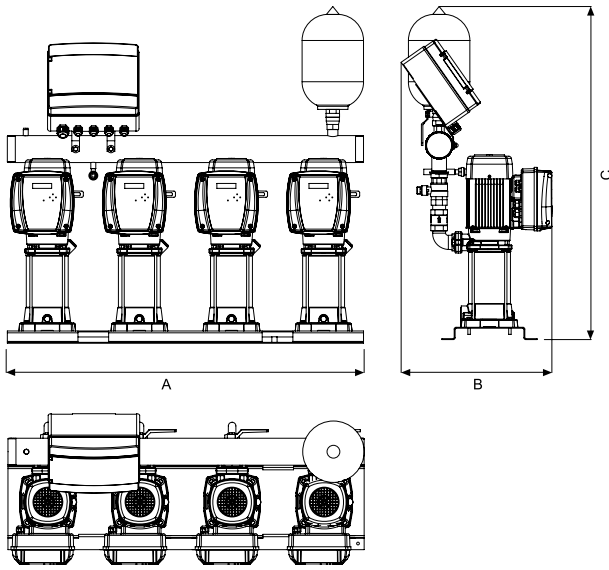

Features table, dimension and weight

Model	Maximum head [m]	Maximum flow [m ³ /h]	P2 [kW]	Speedrive V2	Ø Pump		Ø Manifold	Dimensions			Weight [Kg]	Code	
					Suc.	Dis.		A	B	C		3~400V	3~400V (Model ASP)
CKE 4 Multi 35 4	55	42	1,1	T22	1 1/2"	1 1/4"	3"	1160	464	1044	131	176775	180489
CKE 4 Multi 35 5	67	42	1,5	T22	1 1/2"	1 1/4"	3"	1160	464	1067	142	176776	180488
CKE 4 Multi 35 6	83	42	2,2	T22	1 1/2"	1 1/4"	3"	1160	464	1093	144	176777	180491
CKE 4 Multi 35 8	110	42	3	T55	1 1/2"	1 1/4"	3"	1160	500	1142	172	176778	180490
CKE 4 Multi 35 10	138	42	4	T55	1 1/2"	1 1/4"	4"	1160	500	1170	198	202199	216587
CKE 4 Multi 55 4	51	72	2,2	T22	1 1/2"	1 1/4"	4"	1160	500	1149	156	176781	180529
CKE 4 Multi 55 6	79	72	3	T55	1 1/2"	1 1/4"	4"	1160	533	1228	191	176782	180530
CKE 4 Multi 55 7	93	72	4	T55	1 1/2"	1 1/4"	4"	1160	533	1272	208	173508	180531

Model	Ø Manifold	Ø Valves	Ø Flanges	Code
Kit aspiración para CKE 4 Multi 35	3"	1 1/2"	1 1/2"	207305
Kit aspiración para CKE 4 Multi 55	4"	1 1/2"	1 1/2"	207306

Model	Maximum head [m]	Maximum flow [m ³ /h]	P2 [kW]	Speedrive V2	Ø Pump Suc. / Dis.		Ø Manifold	Dimensions			Weight [Kg]	Code	
					Suc.	Dis.		A	B	C		3~400V	3~400V (Model ASP)
CKE 4 VE 121 3	50	109	4	T55	50	50	4"	1160	550	1147	312	203950	216588
CKE 4 VE 121 5	83	109	5,5	T55	50	50	4"	1160	550	1295	400	203951	216589

Model	Ø Manifold	Ø Valves	Ø Flanges	Code
Kit aspiración para CKE 4 VE 121 3	5"	2"	2"	213986
Kit aspiración para CKE 4 VE 121 5	5"	2"	2"	213987

CKE 4 Multi VS

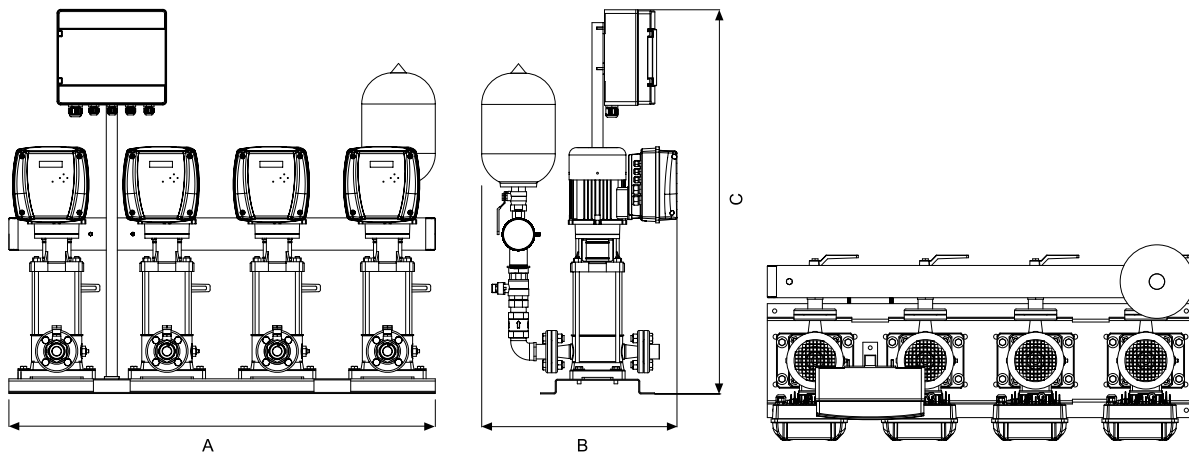

Features table, dimension and weight

Model	Maximum head [m]	Maximum flow [m ³ /h]	P2 [kW]	Speedrive V2	Ø Pump Suc. / Dis.	Ø Manifold	Dimensions			Weight [Kg]	Code	
							A	B	C		3~400V	3~400V (Model ASP)
CKE 4 Multi VS 05 06	45	30	1,1	T22	25	2"	1160	550	915	175	204075	205882
CKE 4 Multi VS 05 09	65	30	1,5	T22	25	2"	1160	550	950	180	204076	205883
CKE 4 Multi VS 05 10	75	30	1,5	T22	25	2"	1160	550	1000	190	204077	205884
CKE 4 Multi VS 05 11	80	30	1,5	T22	25	2"	1160	550	1100	195	204078	205885
CKE 4 Multi VS 05 12	90	30	2,2	T22	25	2"	1160	550	1200	200	204079	205886
CKE 4 Multi VS 05 14	105	30	2,2	T22	25	2"	1160	550	1300	220	204080	205887
CKE 4 Multi VS 05 18	135	30	3	T55	25	2"	1160	550	1600	250	204081	205888
CKE 4 Multi VS 10 04	45	48	1,5	T22	25	3"	1160	550	950	200	204083	205890
CKE 4 Multi VS 10 06	65	48	2,2	T22	25	3"	1160	550	1000	210	204084	205891
CKE 4 Multi VS 10 07	75	48	3	T55	25	3"	1160	550	1050	220	204085	205892
CKE 4 Multi VS 10 08	90	48	3	T55	25	3"	1160	550	1100	230	204052	205893
CKE 4 Multi VS 10 09	100	48	4	T55	25	3"	1160	550	1150	240	204087	205894
CKE 4 Multi VS 10 11	120	48	4	T55	25	3"	1160	550	1200	250	204088	205895
CKE 4 Multi VS 10 13	145	48	5,5	T55	25	3"	1160	550	1200	260	216853	216854
CKE 4 Multi VS 15 03	40	84	3	T55	50	4"	1160	550	1050	240	204092	205897
CKE 4 Multi VS 15 05	70	84	4	T55	50	4"	1160	550	1100	250	204093	205898
CKE 4 Multi VS 15 06	80	84	5,5	T55	50	4"	1160	550	1150	260	204094	205899
CKE 4 Multi VS 15 07	95	84	5,5	T55	50	4"	1160	550	1150	270	216855	216856
CKE 4 Multi VS 20 03	40	108	4	T55	50	5"	1160	550	700	300	204099	205901
CKE 4 Multi VS 20 05	70	108	5,5	T55	50	5"	1160	550	750	340	204100	205902

BOOSTER SETS



Variable speed to maintain the constant pressure and flow that apartment, building or installation demands at every moment.

Sets suitable for all types of motors and power ratings.

Automatic booster set with variable speed for water supply.

Suitable for residential and commercial buildings, industrial applications and agricultural irrigation.

Product range overview

CKDA Set with two pumps.
Flow rate up to 50 m³/h | Pressure up to 200 m.w.c.

CKTA Set with three pumps.
Flow rate up to 75 m³/h | Pressure up to 200 m.w.c.

CKCA Set with four pumps.
Flow rate up to 100 m³/h | Pressure up to 200 m.w.c.

Other configurations and performances on request.

FIRE-FIGHTING SETS



Fire-fighting sets in accordance with the regulations.

More than **60 years of experience** in the sector, a wide range of quality products and a personalized service that responds to all your needs.

Product range overview

- E** Jockey + Electric driven pump.
Flow rate up to 120 m³/h | Pressure up to 90 m.w.c.

- D** Jockey + Diesel driven pump.
Flow rate up to 120 m³/h | Pressure up to 90 m.w.c.

- ED** Jockey + Electric driven pump + Diesel driven pump.
Flow rate up to 120 m³/h | Pressure up to 90 m.w.c.

- DD** Jockey + Two diesel driven pumps.
Flow rate up to 120 m³/h | Pressure up to 90 m.w.c.

Other configurations and performances on request.



A vertical strip on the left side of the page showing a close-up of a water surface with ripples and reflections, transitioning from a dark blue at the top to a lighter turquoise at the bottom.

Recirculation and filtration

The perfect duo
to ensure ever
clean water

A large, abstract graphic on the right side of the page, consisting of a series of curved, overlapping lines that form a pattern of dots and dashes, resembling a stylized wave or a modern architectural element. The pattern is rendered in a lighter shade of red against the background.

Centrifugal single stage pump for water recirculation and filtration

Applications

Water recirculation and filtration for small swimming pools.
Silent.

Materials

Pump body, impeller, diffuser, suction and discharge in technopolymer.
Pump shaft in AISI 431.
Mechanical seal.
Motor casing in aluminum.
O-rings in NBR/EPDM.

Motor

Asynchronous 2 poles.
IPX5 protection.
Class F insulation.
Built-in thermal protection.
Continuous operation.

Range of use

Maximum water temperature 40 °C.
Suitable for salt water up to 7 g/l.

Equipment

2m of cable with plug type F.
Hose connection of 32mm or 38mm.



Hose connection	With cable and plug	Above ground pools	Flow rate up to 4 m ³ /h

Features table

Model	I [A]	P1 [kW]	P2		c [μF]	l/min	10	25	50	75	100	Code
	1~230V	1~	[kW]	[HP]		m ³ /h	0,6	1,5	3	4,5	6	1~230V
Nox 20 4	1	0,2	0,15	0,2	6	mwc	5,3	4,7	3,7	2,7	1,3	203179

Performance curve at 2900 rpm

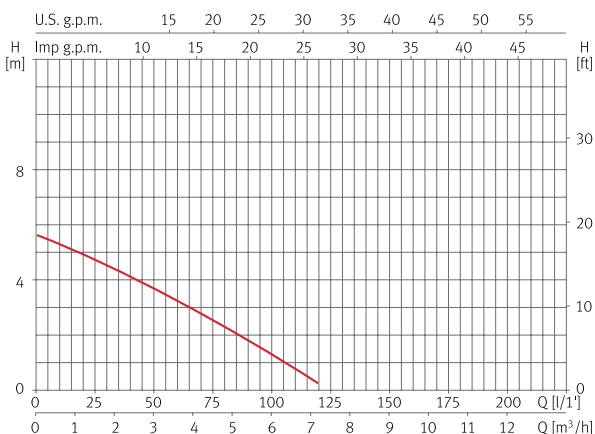

Dimension and weight

Model	A	B	C	D	E/G	F	H/I	J	Kg
Nox 20	305	118	204	94	38	90	32	219	4,5

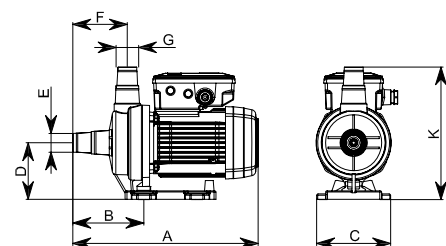

Centrifugal single stage pump for water recirculation and filtration

Applications

Water recirculation and filtration for small swimming pools.
Silent.

Materials

Pump body, impeller, diffuser, suction and discharge in technopolymer.
Pump shaft in AISI 431.
Mechanical seal.
Motor casing in aluminum.
O-rings in NBR/EPDM.

Equipment

2m of cable with plug type F.
Hose connection of 40mm.

Motor

Asynchronous 2 poles.
IPX5 protection.
Class F insulation.
Built-in thermal protection.
Continuous operation.

Range of use

Maximum water temperature 40 °C.
Suitable for salt water up to 7 g/l.



Hose connection



With cable and plug



Above ground pools



Flow rate up to 6 m³/h

Features table

Model	I [A]	P1 [kW]	P2		c [μF]	U/min	10	25	50	75	100	125	150	Code
	1~230V	1~	[kW]	[HP]		m ³ /h	0,6	1,5	3	4,5	6	7,5	9	
Nox 25 6	1,5	0,3	0,18	0,25	6	mwc	9,8	9,6	9,1	8	6,1	3,8	0,6	203180

Performance curve at 2900 rpm

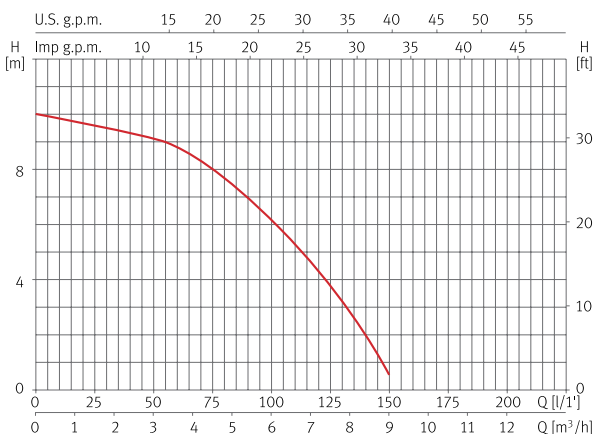

Dimension and weight

Model	A	B	C	D	E/G	F	H	Kg
Nox 25	405	221	158	231	40	158	250	5,1

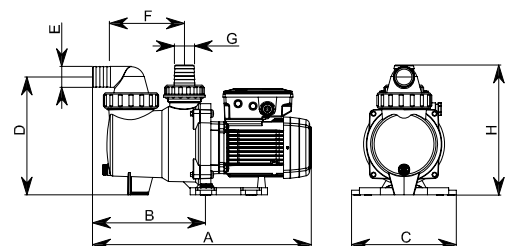

Centrifugal single stage pump for water recirculation and filtration

Applications

Water recirculation and filtration for small swimming pools.
 Silent.
 Self-priming up to 4m.

Materials

Pump body, impeller, diffuser, suction and discharge in technopolymer.
 Pump shaft in AISI 431.
 Mechanical seal.
 Motor casing in aluminum.
 O-rings in NBR/EPDM.

Equipment

2m of cable with plug type F.
 Unions included 50mm.

Motor

Asynchronous 2 poles.
 IPX5 protection.
 Class F insulation.
 Built-in thermal protection.
 Continuous operation.

Range of use

Maximum water temperature 40 °C.
 Suitable for salt water up to 7 g/l.



Quiet



Easy to maintain



With cable and plug



Flow rate up to 15 m³/h

Features table

Model	I [A]	P1 [kW]	P2		c [μF]	l/min									Code
	1~230V	1~	[kW]	[HP]			25	50	75	100	150	200	250	290	
Nox 33 8	2	0,45	0,25	0,33	12	mwc	1,5	3,0	4,5	6,0	9,0	12	15	17,4	1~230V
Nox 50 12	2,8	0,65	0,37	0,5	12		10,2	9,7	8,6	7,2	3,2	-	-	-	203181
Nox 100 15	3,8	0,85	0,75	1	12		12,3	11,9	11,3	10,5	8,1	4,6	-	-	203182
							13,8	13,3	13	12,5	10,8	8,1	4,8	1,8	203183

Performance curve at 2900 rpm

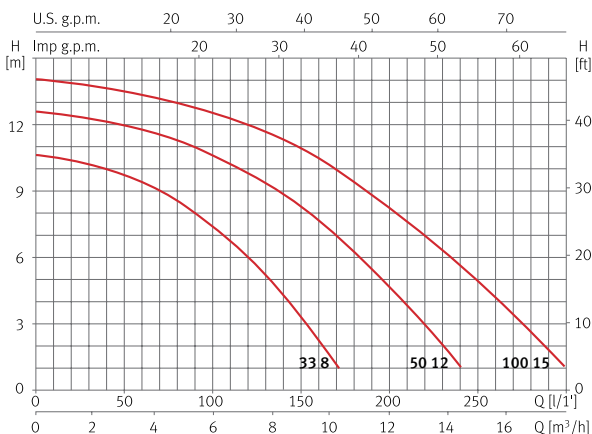

Dimension and weight

Model	A	B	C	D	E	F	G	H	I	J	K	L	Kg
Nox 33	439	192	115	304	210	2 1/4"	221	2 1/4"	264	Ø9	108	212	8,9
Nox 50	439	192	115	304	210	2 1/4"	221	2 1/4"	264	Ø9	108	212	10,2
Nox 100	439	192	115	304	210	2 1/4"	221	2 1/4"	264	Ø9	108	212	10,9

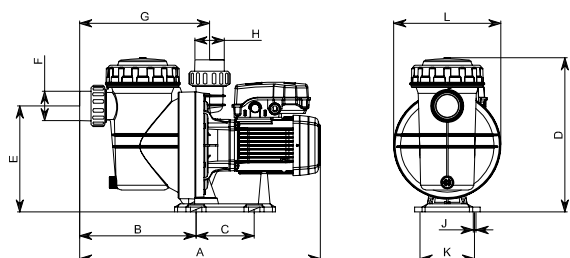

Centrifugal single stage pump for water recirculation and filtration

Applications

Water recirculation and filtration for medium swimming pools.
Silent.
Self-priming up to 4m.

Materials

Pump body, impeller, diffuser, suction and discharge in technopolymer.
Pump shaft in AISI 431.
Mechanical seal.
Motor casing in aluminum.
O-rings in NBR/EPDM.

Equipment

2m of cable with plug type F.
Unions included 50mm.

Motor

Asynchronous 2 poles.
IPX5 protection.
Class F insulation.
Built-in thermal protection.
Continuous operation.

Range of use

Maximum water temperature 40 °C.
Suitable for salt water up to 7 g/l.



Quiet



Easy to maintain



With cable and plug



Flow rate up to 22 m³/h

Features table

Model	I [A]	P1 [kW]	P2		c [μF]	l/min m³/h	40	80	120	160	215	265	325	400	Code
	1~230V	1~	[kW]	[HP]											
Nox 75 15	5,5	1,2	0,55	0,75	16	mwc	15,2	15	14,5	13,1	9,9	6	-	-	203184
Nox 100 18	6	1,4	0,75	1	16		16,9	16,5	16	15	12,9	10	5,9	-	203185
Nox 150 22	7,1	1,6	1,1	1,5	30		18,6	18,2	17,7	16,9	15,1	13	10	5,1	203186

Performance curve at 2900 rpm

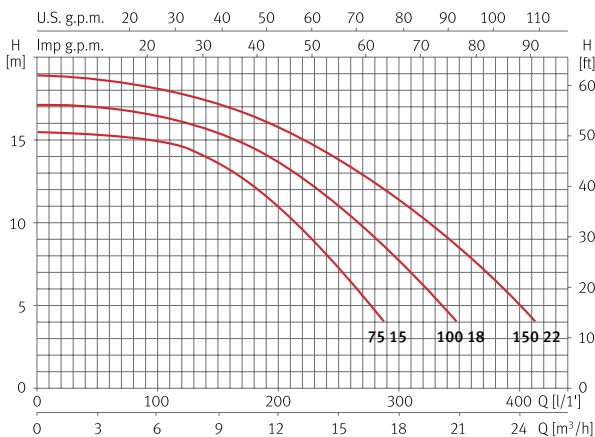

Dimension and weight

Model	A	B	C	D	E/G	F	H	I	J	K	Kg
Nox 75	495	211	170	225	Ø50	225	238	159	Ø9	319	10,2
Nox 100	495	211	170	225	Ø50	225	238	159	Ø9	319	10,9
Nox 150	495	211	170	225	Ø50	225	238	159	Ø9	319	13,5

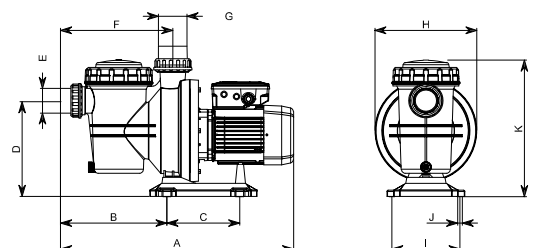

Centrifugal single stage pump for water recirculation and filtration

Applications

Water recirculation and filtration for small swimming pools.
Silent.
Self-priming up to 4m.

Materials

Pump body, impeller, diffuser, suction and discharge in technopolymer.
Pump shaft in AISI 431.
Mechanical seal.
Motor casing in aluminum.
O-rings in NBR/EPDM.

Equipment

No cable.
Unions included 50mm.

Motor

Asynchronous 2 poles.
IPX5 protection.
Class F insulation.
Built-in thermal protection.
Continuous operation.

Range of use

Maximum water temperature 40 °C.
Suitable for salt water up to 7 g/l.



High performance	Quiet	Very reliable	Easy to maintain	Flow rate up to 15 m ³ /h	Best seller

Features table

Model	I [A]	P1 [kW]	P2		c [µF]	l/min m ³ /h	25	50	75	100	150	200	250	290	Code
	1~230V	1~	[kW]	[HP]			1,5	3,0	4,5	6,0	9,0	12	15	17,4	
Silen I 33 8	2	0,45	0,25	0,33	12	10,2	9,7	8,6	7,2	3,2	-	-	-	-	203144
Silen I 50 12	2,8	0,65	0,37	0,5	12	12,3	11,9	11,3	10,5	8,1	4,6	-	-	-	203145
Silen I 100 15	3,8	0,85	0,75	1	12	13,8	13,3	13	12,5	10,8	8,1	4,8	1,8	-	203146

Performance curve at 2900 rpm

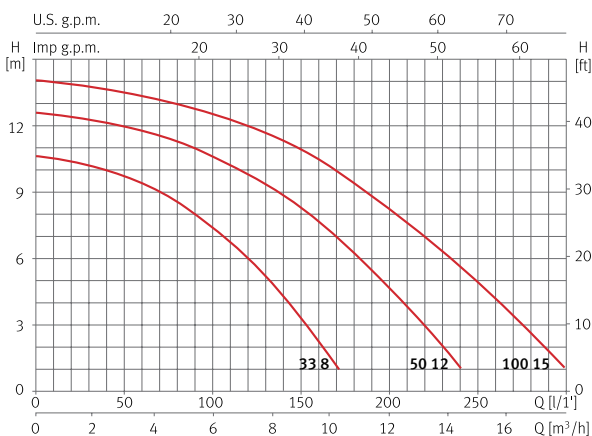

Dimension and weight

Model	A	B	C	D	E/G	F	H	I	J	K	Kg
Silen I 33	439	192	115	210	50	221	212	108	Ø9	304	8,9
Silen I 50	439	192	115	210	50	221	212	108	Ø9	304	10,2
Silen I 100	439	192	115	210	50	221	212	108	Ø9	304	10,9

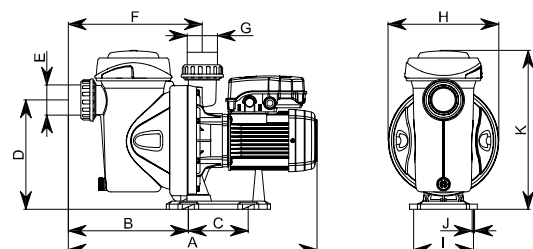

Centrifugal single stage pump for water recirculation and filtration

Applications

Water recirculation and filtration for medium swimming pools.
Silent.
Self-priming up to 4m.

Materials

Pump body, impeller, diffuser, suction and discharge in technopolymer.
Pump shaft in AISI 431.
Mechanical seal.
Motor casing in aluminum.
O-rings in NBR/EPDM.

Equipment

No cable.
Unions included 50mm.

Motor

Asynchronous 2 poles.
IPX5 protection.
Class F insulation.
Single phase motor with built-in thermal protection.
Continuous operation.

Range of use

Maximum water temperature 40 °C.
Suitable for salt water up to 7 g/l.



Quiet



Very reliable



Easy to maintain



Flow rate up to 15 m³/h



Best seller

Features table

Model	I [A]			P1 [kW]		P2		c [μF]	l/min m³/h	40	80	120	160	215	265	325	400	Code	
	1~230V	3~230V	3~400V	1~	3~	[kW]	[HP]			40	80	120	160	215	265	325	400	1~230V	3~230V/400V
Silen S 60 12	3,7	2,4	1,4	0,8	0,8	0,44	0,6	16	mwc	13,6	13,2	12,6	10,9	6,7	-	-	-	203147	203151
Silen S 75 15	5,5	3,3	1,9	1,2	1	0,55	0,75	16		15,2	15	14,5	13,1	9,9	6	-	-	203148	203152
Silen S 100 18	6	3,8	2,2	1,4	1,2	0,75	1	16		16,9	16,5	16	15	12,9	10	5,9	-	203149	203153
Silen S 150 22	7,1	4,8	2,8	1,6	1,6	1,1	1,5	30		18,6	18,2	17,7	16,9	15,1	13	10	5,1	203150	203154

Performance curve at 2900 rpm

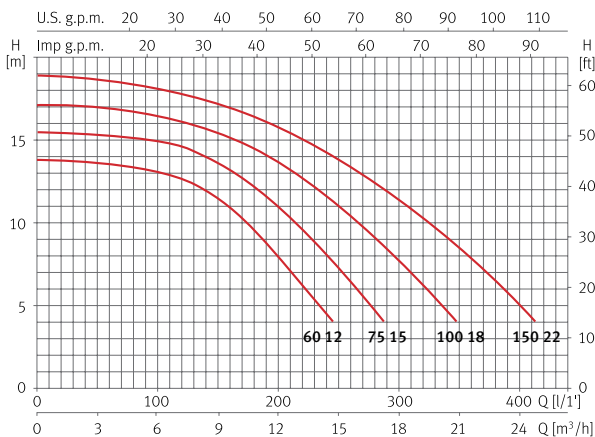

Dimension and weight

Model	A	B	C	D	E	F	G	H	I	J	K	Kg
Silen S 60	555	257	164	225	63	267	50	238	159	Ø9	347	8,9
Silen S 75	555	257	164	225	63	267	50	238	159	Ø9	347	10,2
Silen S 100	555	257	164	225	63	267	50	238	159	Ø9	347	10,9
Silen S 150	577	257	164	225	63	267	50	238	159	Ø9	347	13,5

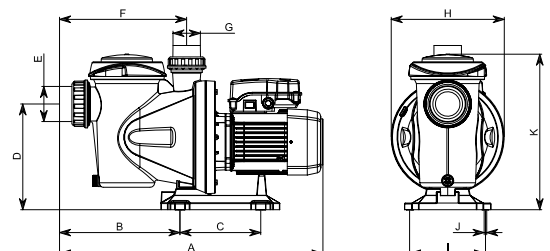

Centrifugal single stage pump for water recirculation and filtration

Applications

Water recirculation and filtration for large swimming pools.
Silent.
Self-priming up to 4m.

Materials

Pump body, impeller, diffuser, suction and discharge in technopolymer.
Pump shaft in AISI 431.
Mechanical seal.
Motor casing in aluminum.
O-rings in NBR/EPDM.

Equipment

No cable.
Unions included 63mm.

Motor

Asynchronous 2 poles.
IPX5 protection.
Class F insulation.
Single phase motor with built-in thermal protection.
Continuous operation.

Range of use

Maximum water temperature 40 °C.
Suitable for salt water up to 7 g/l.



Quiet



Very reliable



Easy to maintain



Flow rate up to 36 m³/h

Features table

Model	I [A]			P1 [kW]		P2		c [µF]	l/ min m³/h	100	150	250	350	450	500	550	650	Code	
	1~ 230V	3~ 230V	3~ 400V	1~	3~	[kW]	[HP]			6,0	9,0	15	21	27	30	33	39	1~230V	3~230V/400V
Silen S2 75 18	4,5	3,8	2,2	1	1	0,55	0,75	25	mwc	13,2	12,8	10	5,5	-	-	-	-	203155	203160
Silen S2 100 24	7	4,8	2,8	1,5	1,6	0,9	1,2	25		16,5	16	14,2	10	4	-	-	-	203156	203161
Silen S2 150 29	8,5	5,3	3,1	1,9	1,9	1,1	1,5	25		18,5	18,2	16,5	13	8,2	5,5	-	-	203157	203162
Silen S2 200 31	9,7	6,5	3,8	2,2	2,2	1,5	2	30		19,5	19,1	18	15	11,1	9	6,3	-	203158	203163
Silen S2 300 36	12,5	8,6	5	2,8	2,6	2,2	3	60		21,5	21	19,9	18	14,9	12,9	10,3	5	203159	203164

Performance curve at 2900 rpm

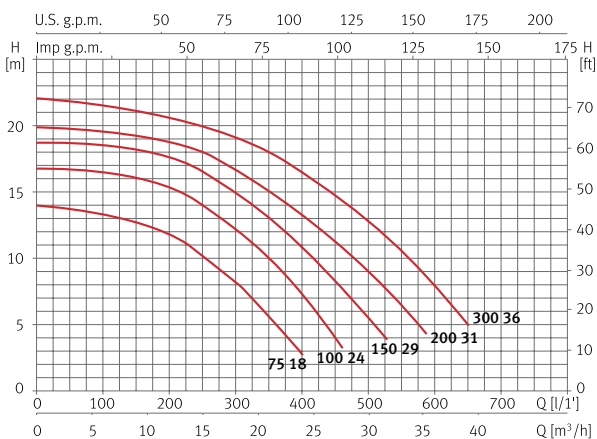

Dimension and weight

Model	A	B	C	D	E/G	F	H	I	J	K	Kg
Silen S2 75	624	272	219	222	63	285	268	188	Ø13	327	14
Silen S2 100	624	272	219	222	63	285	268	188	Ø13	327	15
Silen S2 150	624	272	219	222	63	285	268	188	Ø13	327	18
Silen S2 200	624	272	219	222	63	285	268	188	Ø13	327	21
Silen S2 300	624	272	219	222	63	285	268	188	Ø13	327	23

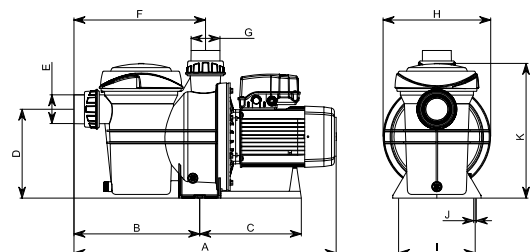

Centrifugal single stage pump for seawater recirculation and filtration

Applications

Seawater recirculation and filtration for small and medium swimming pools.
Silent.
Self-priming up to 4m.

Materials

Pump body, impeller, diffuser, suction and discharge in technopolymer.
DUPLEX pump shaft.
Special mechanical seal for seawater.
Aluminium motor shield coated with cataphoresis treatment.
AISI 316 screws.
NBR seals.

Equipment

2m of cable with plug type F.
Unions included 50mm.

Motor

Asynchronous 2 poles.
IPX5 protection.
Class F insulation.
Built-in thermal protection.
Continuous operation.

Range of use

Maximum water temperature 40 °C.
Compatible with seawater.



Quiet	Easy to maintain	With cable and plug	Flow rate up to 22 m ³ /h	Designed for seawater

Features table

Model	I [A]	P1 [kW]	P2		c [μF]	l/min	40	80	120	160	215	265	325	400	Code
	1~230V	1~	[kW]	[HP]			m ³ /h	2,4	4,8	7,2	9,6	12,9	15,9	19,5	
Noxsalt 75 15	5,5	1,2	0,55	0,75	16	mwc	15,2	15	14,5	13,1	9,9	6	-	-	217166
Noxsalt 100 18	6	1,4	0,75	1	16		16,9	16,5	16	15	12,9	10	5,9	-	217167
Noxsalt 150 22	7,1	1,6	1,1	1,5	30		18,6	18,2	17,7	16,9	15,1	13	10	5,1	217172

Performance curve at 2900 rpm

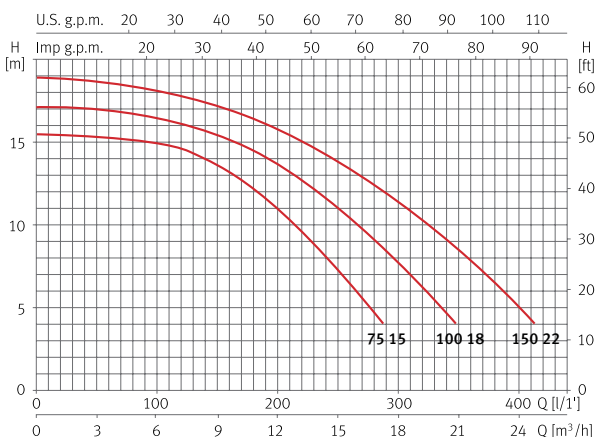

Dimension and weight

Model	A	B	C	D	E	F/G	H	I	J	K	Kg
Noxsalt 75	495	211	170	225	225	50	238	159	319	Ø9	10,2
Noxsalt 100	495	211	170	225	225	50	238	159	319	Ø9	10,9
Noxsalt 150	495	211	170	225	225	50	238	159	319	Ø9	13,5

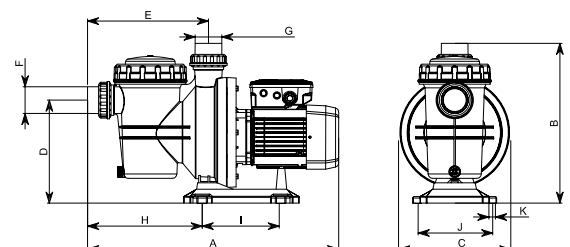

Centrifugal single stage pump with variable speed for seawater recirculation and filtration

Applications

Seawater recirculation and filtration for small and medium swimming pools.
Silent.
Self-priming up to 4m.

Materials

Pump body, impeller, diffuser, suction and discharge in technopolymer.
DUPLEX pump shaft.
Special mechanical seal for seawater.
Aluminium motor shield coated with cataphoresis treatment.
AISI 316 screws.
NBR seals.

Equipment

2m of cable with plug type F.
Unions included 50mm.

Motor

Asynchronous 2 poles.
IPX5 protection.
Class F insulation.
Built-in thermal protection.
Continuous operation.

Range of use

Maximum water temperature 40 °C.
Compatible with seawater.

Funcionamiento

Speed variation to adapt to the swimming pool working cycles.



Energy savings up to 70%	Longer service life	Ultra-quiet	Easy to use	Better filtration and water quality	Designed for seawater

Features table

Model	Speed	I [A]	P1 [kW]	P2		l/min	50	100	150	200	250	Code
		1~230V	1~	[kW]	[HP]							
Noxsalt plus	High	7,6	1,1	0,75	1	mwc	15,5	15	14	13	11	217173
	Medium	3	0,4									
	Low	1,2	0,16									

Performance curve

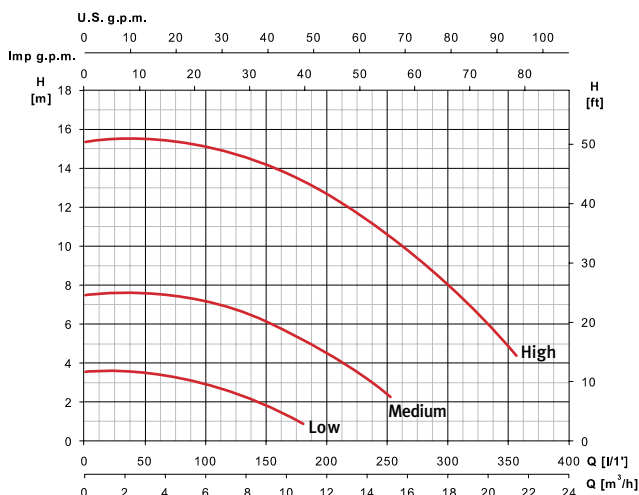

Dimension and weight

Model	A	B	C	D	E	F/G	H	I	J	K	Kg
Noxsalt plus	549	346	238	223	262	50	170	Ø9	159	248	12,8

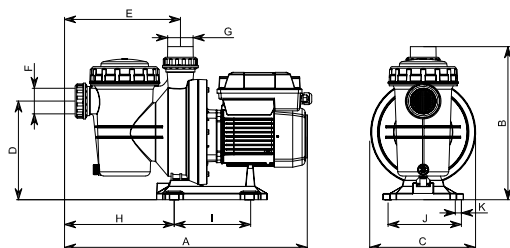

Centrifugal single stage pump with variable speed for water recirculation and filtration

Applications

Water recirculation and filtration for small and medium swimming pools.
Silent.
Self-priming up to 4m.

Materials

Pump body, impeller, diffuser, suction and discharge in technopolymer.
Pump shaft in AISI 431.
Mechanical seal.
Motor casing in aluminum.
O-rings in NBR/EPDM.

Equipment

2m of cable with plug type F.
Unions included 50mm.

Motor

Asynchronous 2 poles.
IPX5 protection.
Class F insulation.
Built-in thermal protection.
Continuous operation.

Range of use

Maximum water temperature 40° C.
Suitable for salt water up to 7 g/l.

Operation

Speed variation to adapt to the swimming pool working cycles.



Energy savings up to 70%	Longer service life	Ultra-quiet	Easy to use	Better filtration and water quality

Features table

Model	Speed	I [A]	P1 [kW]	P2		l/min m³/h	50	100	150	200	250	Code
		1~ 230V	1~	[kW]	[HP]							
Noxplus	High	7,6	1,1	0,75	1	mwc	15,5	15	14	13	11	214856
	Medium	3	0,4									
	Low	1,2	0,16									

Performance curve

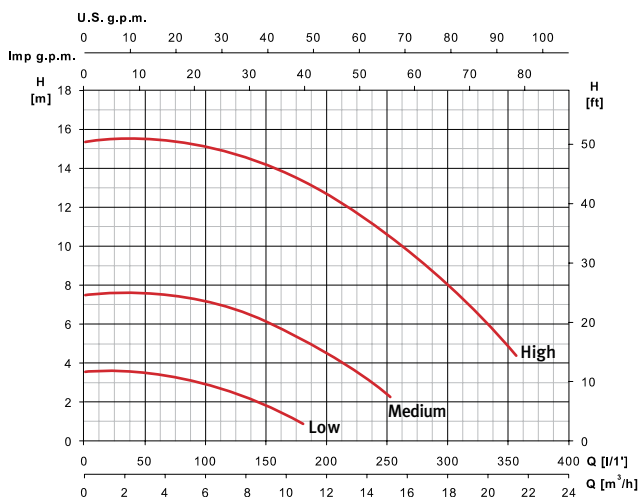

Dimension and weight

Model	A	B	C	D	E	F/G	H	I	J	K	Kg
Noxplus	549	346	238	223	262	50	170	Ø9	159	248	12,8

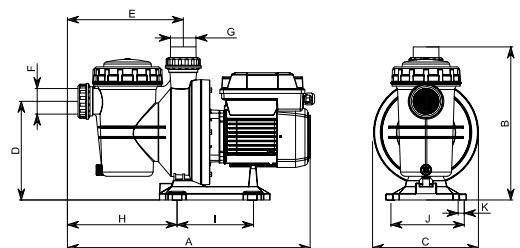

Noxplus 2 **Recirculation and filtration | Recirculation**



Centrifugal single stage pump with variable speed for water recirculation and filtration

Applications

Water recirculation and filtration for medium and large swimming pools.
Silent.
Self-priming up to 4m.

Materials

Pump body, impeller, diffuser, suction and discharge in technopolymer.
Pump shaft in AISI 431.
Mechanical seal.
Motor casing in aluminum.
O-rings in NBR/EPDM.

Equipment

2m of cable with plug type F.
Unions included 63mm.

Motor

Asynchronous 2 poles.
IPX5 protection.
Class F insulation.
Built-in thermal protection.
Continuous operation.

Range of use

Maximum water temperature 40° C.
Suitable for salt water up to 7 g/l.

Operation

Speed variation to adapt to the swimming pool working cycles.



Energy savings up to 70%



Longer service life



Ultra-quiet



Easy to use



Better filtration and water quality

Features table

Model	Speed	I [A]	P1 [kW]	P2		l/min m ³ /h	100	200	250	300	400	Code
		1~ 230V	1~	[kW]	[HP]							
Noxplus 2	High	10	1,5				15	13,5	12,5	11	7	216726
	Medium	5,3	0,75	1,5	2	mwc	9	7,5	6	5	-	
	Low	2	0,25				4	2,5	1	-	-	

Performance curve

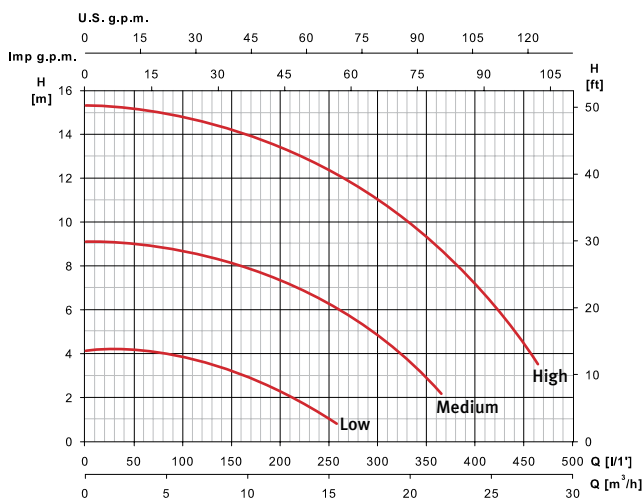

Dimension and weight

Model	A	B	C	D	E/G	F	H	I	J	K	Kg
Noxplus 2	624	272	327	222	63	285	326	Ø13	268	188	18,5

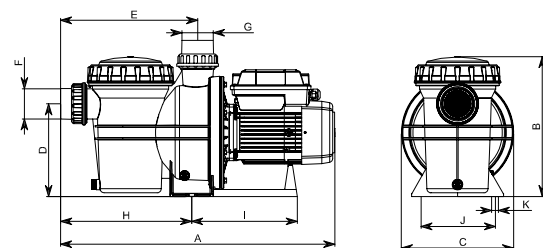

Silenplus 1 **Recirculation and filtration** | Recirculation



Centrifugal single stage pump with variable speed for water recirculation and filtration

Applications

Water recirculation and filtration for medium swimming pools.
Silent.
Self-priming up to 4m.

Materials

Pump body, impeller, diffuser, suction and discharge in technopolymer.
Pump shaft in AISI 431.
Mechanical seal.
Motor casing in aluminum.
O-rings in NBR/EPDM.

Equipment

Control System included.
2m of cable with plug type F.
Unions included 50mm.

Motor

Asynchronous 2 poles.
IPX5 protection.
Class F insulation.
Built-in thermal protection.
Continuous operation.

Range of use

Maximum water temperature 40° C.
Suitable for salt water up to 7 g/l.

Operation

Automatic speed variation to adapt to the swimming pool working cycles.

Control System

Device that transmits the valve's position to the pump so that it activates the working cycle according to the valve's position.



Download ESPA Evopool App for a better experience and management



Energy savings up to 80%	Longer service life	Ultra-quiet	Better filtration and water quality	Better backwashing	App - Easy management

Features table

Model	Speed	I [A]	P1 [kW]	P2		l/min	50	100	150	200	250	Code
		1~230V	1~	[kW]	[HP]	m³/h	3	6	9	12	15	1~230V
Silenplus 1	Maximum	8	1,1	0,75	1	mwc	17	16,5	14,5	13,8	11	199398
	Minimum	1	0,1				2,5	1,5	-	-	-	

Performance curve

Speed	1	2	3	4	5	6	7	8	9	10
Consumption [A]	1	1,3	1,7	2,5	3,1	3,7	4,5	5,5	6,5	8

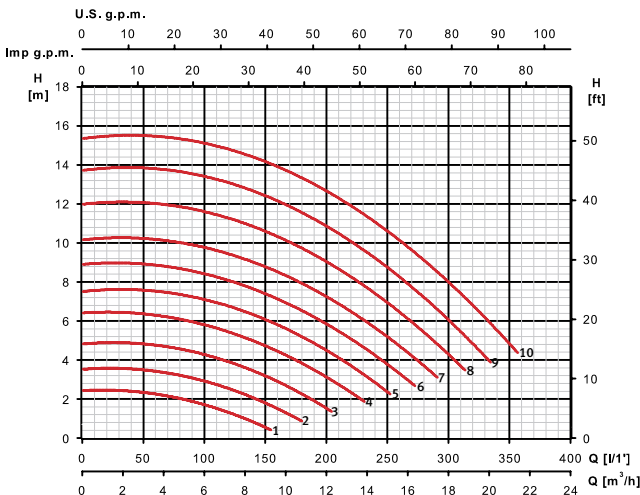

Dimension and weight

Model	A	B	C	D	E	F	G	H	I	J	K	Kg
Silenplus 1	555	257	164	225	63	267	50	238	159	Ø9	319	11,8

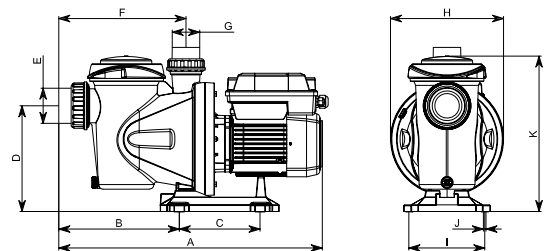

Accessories	Code
PCBA home automation circuit	214755

Silenplus 2 **Recirculation and filtration** | Recirculation



Centrifugal single stage pump with variable speed for water recirculation and filtration

Applications

Water recirculation and filtration for medium and large swimming pools.
Silent.
Self-priming up to 4m.

Materials

Pump body, impeller, diffuser, suction and discharge in technopolymer.
Pump shaft in AISI 431.
Mechanical seal.
Motor casing in aluminum.
O-rings in NBR/EPDM.

Equipment

Control System included.
2m of cable with plug type F.
Unions included 63mm.

Motor

Asynchronous 2 poles.
IPX5 protection.
Class F insulation.
Built-in thermal protection.
Continuous operation.

Range of use

Maximum water temperature 40° C.
Suitable for salt water up to 7 g/l.

Operation

Automatic speed variation to adapt to the swimming pool working cycles.

Control System

Device that transmits the valve's position to the pump so that it activates the working cycle according to the valve's position.



Download ESPA Evopool App for a better experience and management



Energy savings up to 80%	Longer service life	Ultra-quiet	Better filtration and water quality	Better backwashing	App - Easy management

Features table

Model	Speed	I [A]	P1 [kW]	P2		l/min	100	200	250	300	400	Code
		1~230V	1~	[kW]	[HP]							
Silenplus 2	Maximum	10	2,2	1,5	2	mwc	15	13,5	12,5	11,5	7,5	199399
	Minimum	1,2	0,17				2	1	-	-	-	

Performance curve

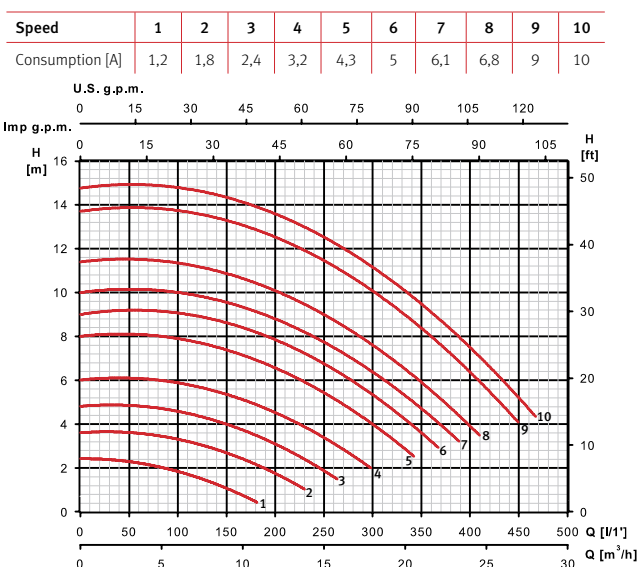

Dimension and weight

Model	A	B	C	D	E/G	F	H	I	J	K	Kg
Silenplus 2	624	272	253	222	63	285	268	188	Ø13	327	21,9

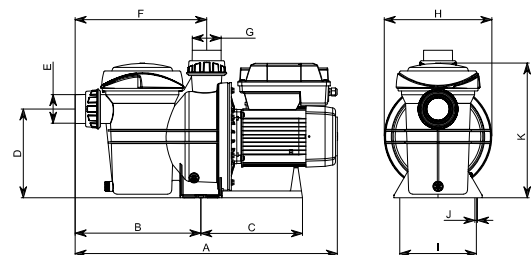

Accessories	Code
PCBA home automation circuit	214755

Silenplus 3 **Recirculation and filtration** | Recirculation



Centrifugal single stage pump with variable speed for water recirculation and filtration

Applications

Water recirculation and filtration for large swimming pools.
Silent.
Self-priming up to 4m.

Materials

Pump body, impeller, diffuser, suction and discharge in technopolymer.
Pump shaft in AISI 431.
Mechanical seal.
Motor casing in aluminum.
O-rings in NBR/EPDM.

Equipment

Control System included.
2m of cable with plug type F.
Unions included 63mm.

Motor

Asynchronous 2 poles.
IPX5 protection.
Class F insulation.
Built-in thermal protection.
Continuous operation.

Range of use

Maximum water temperature 40° C.
Suitable for salt water up to 7 g/l.

Operation

Automatic speed variation to adapt to the swimming pool working cycles.

Control System

Device that transmits the valve's position to the pump so that it activates the working cycle according to the valve's position.



Download ESPA Evopool App for a better experience and management



Energy savings up to 80%	Longer service life	Ultra-quiet	Better filtration and water quality	Better backwashing	App - Easy management

Features table

Model	Speed	I [A]	P1 [kW]	P2		l/min	100	200	300	400	600	Code
		1~230V	1~	[kW]	[HP]	m³/h	6	12	18	24	36	1~230V
Silenplus 3	Maximum	14,8	2,6	2,2	3	mwc	21,5	20,5	19	16,5	8	200519
	Minimum	1,6	0,2				3,5	2,5	-	-	-	

Performance curve

Speed	1	2	3	4	5	6	7	8	9	10
Consumption [A]	1,6	2,3	3,4	4,6	5,7	7,3	8,6	10,5	12,3	14,8

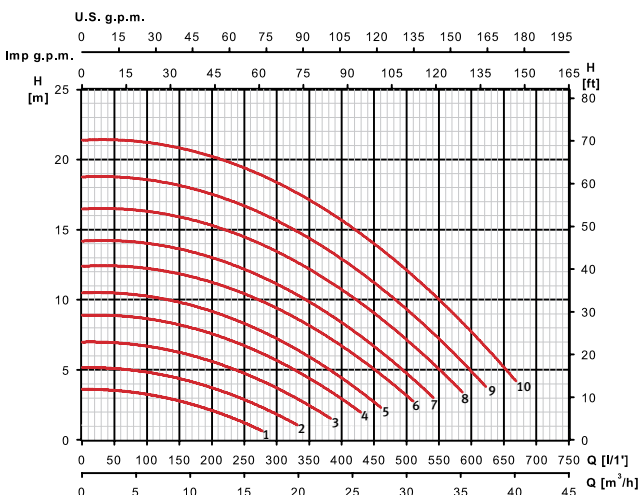

Dimension and weight

Model	A	B	C	D	E/G	F	H	I	J	K	Kg
Silenplus 3	624	272	253	222	63	285	268	188	Ø13	368	23,9

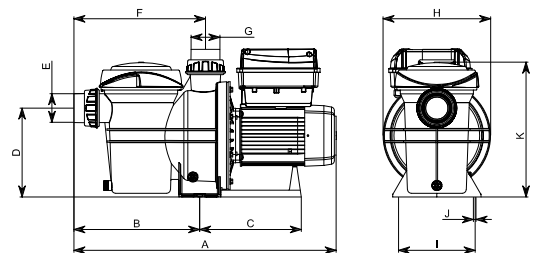

Accessories	Code
PCBA home automation circuit	214755

Set for water recirculation and filtration

Applications

Water recirculation and filtration for small swimming pools.
Silent.

Materials

Pump:

Pump body, impeller, diffuser, suction and discharge in technopolymer.
Pump shaft in AISI 431.
Mechanical seal.
Motor casing in aluminum.

Filter:

Polyethylene.

Motor

Asynchronous 2 poles.
IPX5 protection.
Class F insulation.
Built-in thermal protection.
Continuous operation.

Range of use

Maximum water temperature 40 °C.
Suitable for salt water up to 7 g/l.

Equipment

2m of cable with plug type F.
Fittings, base and valve.
Unions included.



Set completo

Easy to install

Above ground pools

Features table

Model	Pump							Filter				Code			
	I [A] 1~ 230V	P1 [kW] 1~	P2 [kW]	P2 [HP]	c [µF]	Ø suc. [mm]	l/min m³/h	50 3	100 6	150 9	Ø filter [mm]	Flow [m³/h]	Sand load [Kg]	Valve connection	1~230V
Neat 300	1	0,2	0,15	0,2	6	38	mwc	3,7	1,3	-	300	4	25	1 1/2"	203199
Neat 350	1,5	0,3	0,18	0,25	6	40		9,1	6,1	0,6	350	6	35	1 1/2"	203200
Neat 450	2	0,45	0,25	0,33	12	50		9,7	7,2	3,2	450	8	75	1 1/2"	203201

Performance curve at 2900 rpm

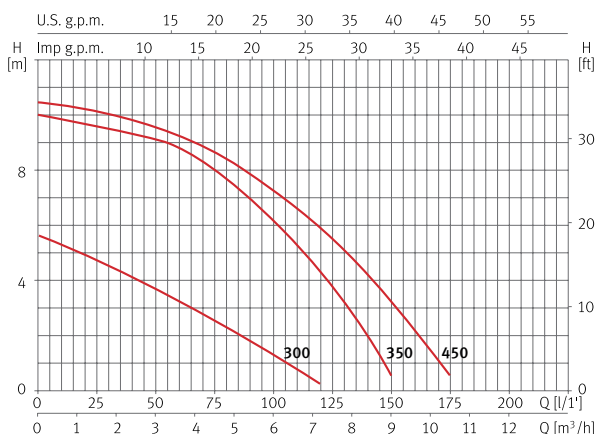

Dimension and weight

Model	A	B	C	D	E	Kg
Neat 300	350	613	734	584	586	10
Neat 350	350	613	758	575	635	12
Neat 450	350	613	853	670	730	16

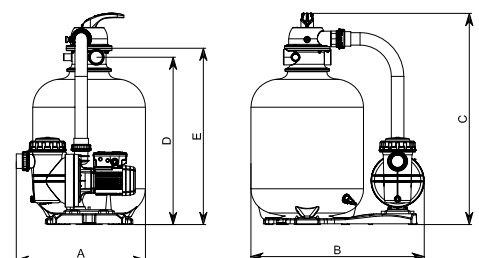

Sand filter for water filtration

Filterkit Base

Filter with valve made of polyethylene resistant to chemical and weather agents.
Blow moulded in single piece with base built into the filter.
With top mount 6-way valve.

Features

Maximum working pressure 2,5 bar.
Connection of 1½".
Fitted with pressure gauge and air valve.
Double drainage in the lower section of the filter, ½" to totally empty the filter and ¼" to empty water without loss of sand.
Suitable for salt water up to 7 g/l.



Residential swimming pool

Features table

Model	Filter			Code
	Ø filter [mm]	Flow [m³/h]	Sand load [Kg]	
FKB 350 6TP	350	6	35	160863
FKB 450 6TP	450	8	75	134538
FKB 550 6TP	550	12	100	134539

Dimension and weight

Model	A	B	C	Kg
FKB 350 6TP	350	735	258	5,6
FKB 450 6TP	450	832	330	7,7
FKB 550 6TP	550	832	440	10,1



Accessories	Code
Kit valve 6TP 1½"	149974

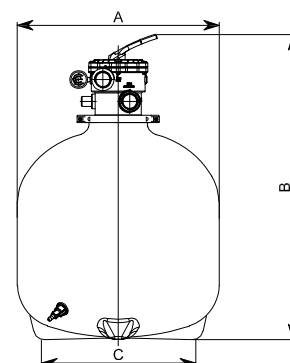

Sand filter for water filtration

Filterkit Plus

Filter with valve made of polypropylene resistant to chemical and weather agents.
Injection moulded with the two halves thermally welded.
With side mount 6-way valve.

Features

Maximum working pressure 3,5 bar.
Connection of 1½" for 520 and 620 models and 2" connection for 760 model.
Fitted with pressure gauge and air valve.
Double drainage in the lower section of the filter, 1½" to totally empty the filter and ½" to empty water without loss of sand.
Suitable for salt water up to 7 g/l.



Very reliable



Robust



Residential swimming pool

Features table

Model	Filter			Code
	Ø filter [mm]	Flow [m³/h]	Sand load [Kg]	
FKP 520 6LT	520	10	85	130906
FKP 620 6LT	620	14	145	130907
FKP 760 6LT	760	21	300	130908

Dimension and weight

Model	A	B	C	D	E	Ø	Kg
FKP 520 6LT	844	886	422	460	519	520	21,7
FKP 620 6LT	943	957	422	501	560	620	23,7
FKP 760 6LT	1.102	1.114	422	630	715	767	34



Accessories	Code
Kit valve 6LT 1½"	149976
Kit valve 6LT 2"	149977

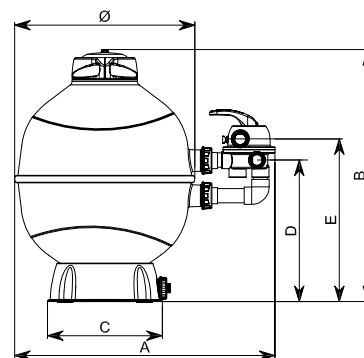

Centrifugal multistage pump for pool cleaners

Applications

Booster pump for pool cleaners.
Designed to operate with chlorinated and salty water.

Materials

Pump body, diffusers, suction and discharge in technopolymer.
Impellers in AISI 316.
Pump shaft in AISI 431.
Mechanical seal.
Motor casing in aluminum.
O-rings in NBR/EPDM.

Equipment

No cable.

Motor

Asynchronous 2 poles.
IPX5 protection.
Class F insulation.
Built-in thermal protection.
Continuous operation.

Range of use

Maximum water temperature 40 °C.
Suitable for salt water up to 7 g/l.



Features table

Model	I [A]	P1 [kW]	P2		c [μF]	l/min	10	30	40	50	60	65	70	80	Code
	1~230V	1~	[kW]	[HP]		m³/h	0,6	1,8	2,4	3,0	3,6	3,9	4,3	4,8	
Multipool N	6	1,3	0,75	1	16	mwc	53	47	43	37	32	28	24	17	202038

Performance curve at 2900 rpm

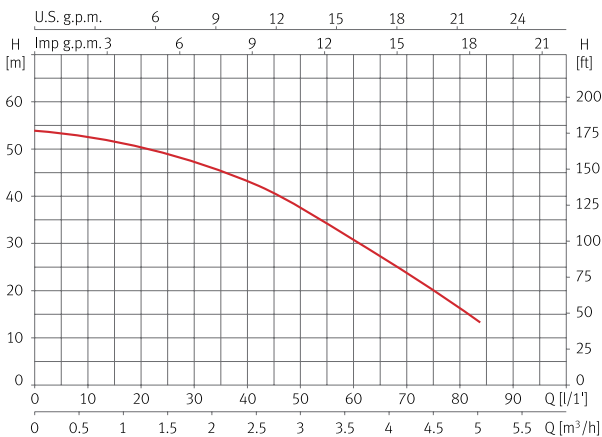

Dimension and weight

Model	A	B	C	D	E	F/G	H	I	J	K	Kg
Multipool N	415	248	190	155	120	1"	198	225	94	Ø9	10,5

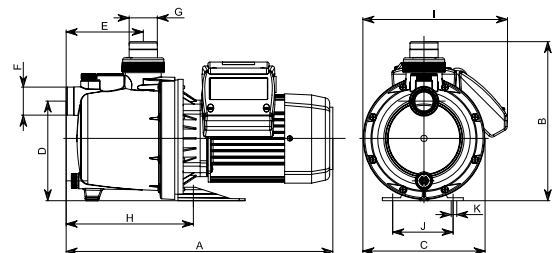

Centrifugal single stage pump for water stream

Applications

Generation of a strong water stream to transform swimming pools into a place for sport and leisure.
Self-priming up to 4m.

Materials

Pump body, impeller, diffuser, suction and discharge in technopolymer.
Pump shaft in AISI 431.
Mechanical seal.
Motor casing in aluminum.
O-rings in NBR/EPDM.

Equipment

No cable.
Unions not included.

Motor

Asynchronous 2 poles.
IPX5 protection.
Class F insulation.
Single phase motor with built-in thermal protection.
Continuous operation.

Range of use

Maximum water temperature 40 °C.
Suitable for salt water up to 7 g/l.

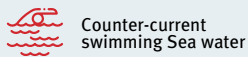

Features table

Model	I [A]			P1 [kW]		P2		c [μF]	l/min									Code	
	1~230V	3~230V	3~400V	1~	3~	[kW]	[HP]			m³/h	100	200	400	600	800	1000	1200	1300	1~230V
Nadorself 200	10,2	7	4,1	2,2	2,2	1,5	2	40	mwc	12,9	12,2	10,6	8,5	6	-	-	-	203165	203167
Nadorself 300	13,4	8,6	5	3	3	2,2	3	60		14,6	14	12,8	11,3	9	6,5	-	-	203166	203168
Nadorself 400	-	11,8	6,8	-	3,4	3	4	-		17,2	16,6	15,3	13,8	11,6	9,4	6,3	4,5	-	203169

Performance curve at 2900 rpm

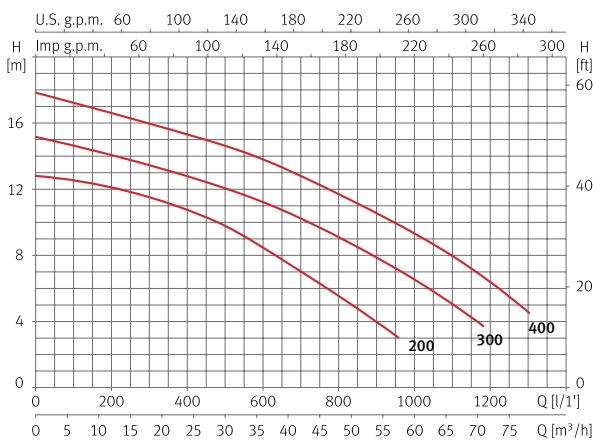

Dimension and weight

Model	A	B	C	D	E	F/G	H	I	J	K	Kg
Nadorself 200	615	416	335	249	291	2 1/2"	419	70	595	Ø9	25,1/23,1
Nadorself 300	615	416	335	249	291	2 1/2"	419	70	595	Ø9	26,1/25,8
Nadorself 400	615	416	335	249	291	2 1/2"	419	70	595	Ø9	28

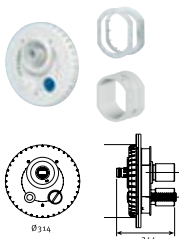
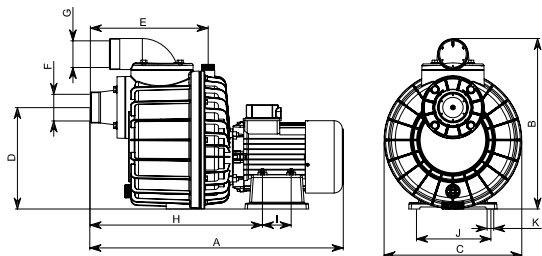

Accessories	Code
Suction and discharge circular kit	128188
Bushing wall kit for liner and concrete pools	146558



Centrifugal single stage pump for water recirculation

Applications

Water recirculation in swimming pools, spas and whirlpools.

Materials

Pump body, impeller, diffuser, suction and discharge in technopolymer.
Pump shaft in AISI 431.
Mechanical seal.
Motor casing in aluminum.
O-rings in NBR/EPDM.

Equipment

No cable.
Tiper: unions included, suction 50mm and discharge 32mm x2.
Tiper 2: unions included, suction 50mm and discharge 40mm x2.

Motor

Asynchronous 2 poles.
IPX5 protection.
Class F insulation.
Built-in thermal protection.
Continuous operation.

Range of use

Maximum water temperature 50 °C.
Suitable for salt water up to 7 g/l.



Tiper



Tiper 2

Features table

Model	I [A]	P1 [kW]	P2		c [μF]	l/min m³/h	50	100	150	200	250	300	350	400	Code
	1~230V	1~	[kW]	[HP]			3	6	9	12	15	18	21	24	
Tiper 70	3	0,7	0,37	0,5	12	mwc	8,8	7,9	6,7	5,4	3,9	2,3	-	-	208183
Tiper 90	3,8	0,9	0,75	1	12		9,3	8,5	7,6	6,4	5,1	3,6	2,2	-	208184
Tiper 2 75	5,3	1,2	0,55	0,75	16		14	12,5	11	10	7,5	6	4	-	137549
Tiper 2 125	5,6	1,5	0,9	1,2	16		15	14	12,5	11,5	10	8	6	4	137548

Performance curve at 2900 rpm

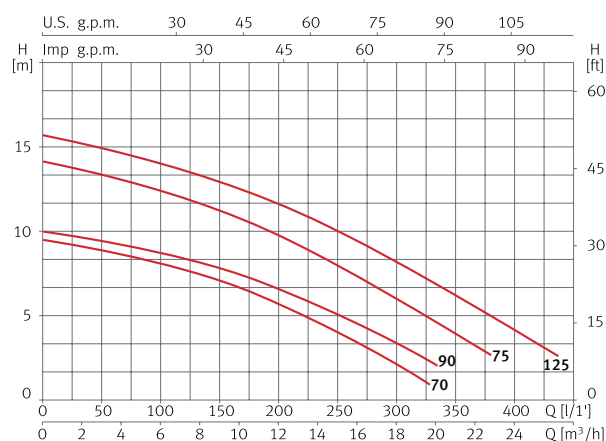

Dimension and weight

Model	A	B	C	D	E	F	G	H	I	J	K	Kg
Tiper 70	312	202	166	47	88	50	32	160	-	102	Ø8	6,2
Tiper 90	312	202	166	47	88	50	32	160	-	101	Ø8	7,0
Tiper 2 75	378	215	187	50	120	50	50	130	120	124	Ø8	9,5
Tiper 2 125	378	265	187	50	120	50	40	120	130	124	Ø8	10,5

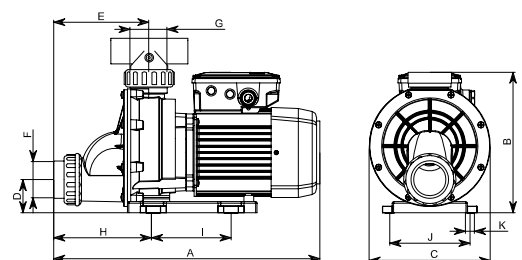

Centrifugal single stage pump for water recirculation

Applications

Water recirculation in swimming pools, spas and whirlpools.

Materials

Pump body, impeller, diffuser, suction and discharge in technopolymer.
Pump shaft in AISI 431.
Mechanical seal.
Motor casing in aluminum.
O-rings in NBR/EPDM.

Motor

Asynchronous 2 poles.
IPX5 protection.
Class F insulation.
Built-in thermal protection.
Continuous operation.

Range of use

Maximum water temperature 50 °C.
Suitable for salt water up to 7 g/l.

Equipment

No cable.
Unions included 50mm.



Features table

Model	I [A]	P1 [kW]	P2		c [μF]	l/min	25	50	100	150	200	250	300	350	Code
	1~230V	1~	[kW]	[HP]			m³/h	1,5	3,0	6,0	9,0	12	15	18	
Wiper 50	2,3	0,5	0,24	0,33	12	mwc	10	9,4	7,9	6	3,6	1	-	-	215079
Wiper 70	2,9	0,65	0,37	0,5	12		11	10,6	9,7	8,5	6,6	4,5	2,2	-	215080
Wiper 90	3,7	0,85	0,75	1	12		11,7	11,3	10,5	9,6	8,4	6,7	4,6	2,2	215081

Performance curve at 2900 rpm

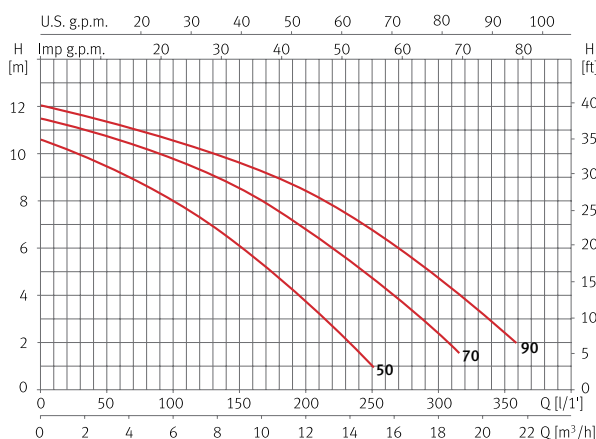

Dimension and weight

Model	A	B	C	D	E	F/G	H	I	J	K	Kg
Wiper 50	296	177	155	85	72	50	145	74	102	Ø9	5,7
Wiper 70	296	177	155	85	72	50	145	74	102	Ø9	6
Wiper 90	296	177	155	85	72	50	145	74	102	Ø9	6,9

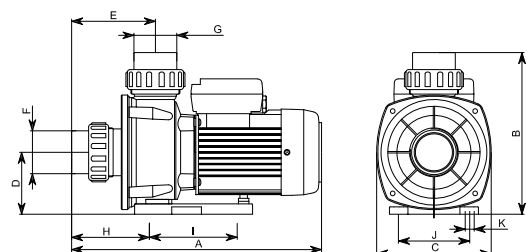

Centrifugal single stage pump for water recirculation

Applications

Water recirculation in swimming pools, spas and whirlpools.

Materials

Pump body, impeller, diffuser, suction and discharge in technopolymer.
Pump shaft in AISI 431.
Mechanical seal.
Motor casing in aluminum.
O-rings in NBR/EPDM.

Equipment

No cable.
Unions included 63mm.

Motor

Asynchronous 2 poles.
IPX5 protection.
Class F insulation.
Single phase motor with built-in thermal protection.
Continuous operation.

Range of use

Maximum water temperature 50 °C.
Suitable for salt water up to 7 g/l.



Features table

Model	I [A]			P1 [kW]		P2		c [μF]	l/min	50	100	200	300	400	500	600	900	Code		
	1~230V	3~230V	3~400V	1~	3~	[kW]	[HP]											1~230V	3~230V/400V	
Wiper 3 150	6,4	5	2,9	1,4	1,1	1,1	1,5	25												
Wiper 3 200	8,8	6,6	3,8	2	1,8	1,5	2	30												
Wiper 3 300	11	7,1	4,1	2,5	2,4	2,2	3	60												

Performance curve at 2900 rpm

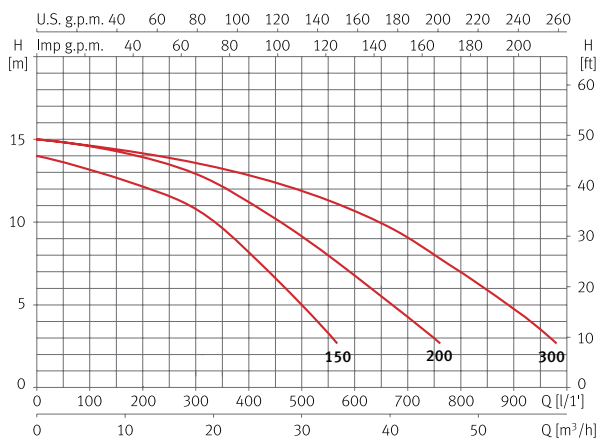

Dimension and weight

Model	A	B	C	D	E	F/G	H	I	J	K	L	Kg
Wiper 3 150	429	230	191	108	130	63	160	120	124	Ø9	29	14,3
Wiper 3 200	429	230	191	108	130	63	160	120	124	Ø9	29	17
Wiper 3 300	429	268	191	108	130	63	160	120	124	Ø9	29	18,8

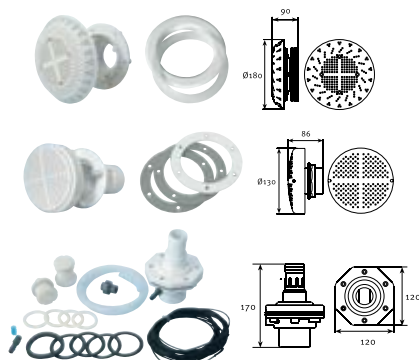
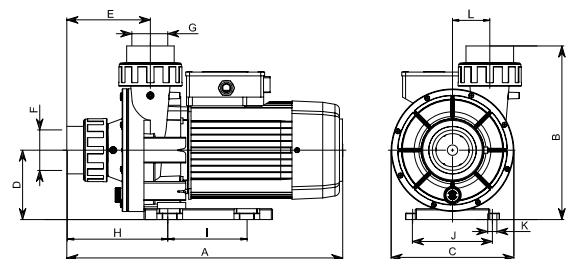

Accessories	Code
Suction kit for liner pools	130634
Suction kit for concrete pools	130633
Discharge kit for liner and concrete pools	130632
Hose kit 1,5m	104153

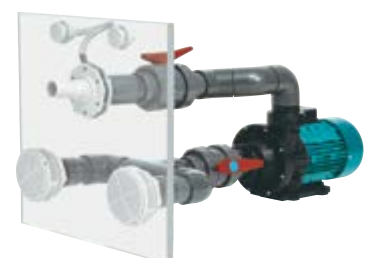

Centrifugal single stage pump for salt water recirculation

Applications

Clean water recirculation.
Suitable for salt water.

Materials

Pump body, impeller, diffuser, suction and discharge in technopolymer.
Pump shaft in AISI 431.
Mechanical seal.
Motor casing in aluminum.
O-rings in NBR/EPDM.

Motor

Asynchronous 2 poles.
IPX5 protection.
Class F insulation.
Built-in thermal protection.
Continuous operation.

Range of use

Maximum water temperature 40 °C.

Equipment

No cable.
Unions included 50mm.
Hose connection of 40mm.



Hose connection included



Features table

Model	I [A]	P1 [kW]	P2		c [μF]	l/min m³/h	25	50	100	150	200	250	300	Code
	1~230V	1~	[kW]	[HP]			1,5	3,0	6,0	9,0	12	15	18	
Piscis 3	3,1	0,7	0,55	0,75	10	mwc	11	10,6	9,7	8,5	6,6	4,5	2,2	215143

Performance curve at 2900 rpm

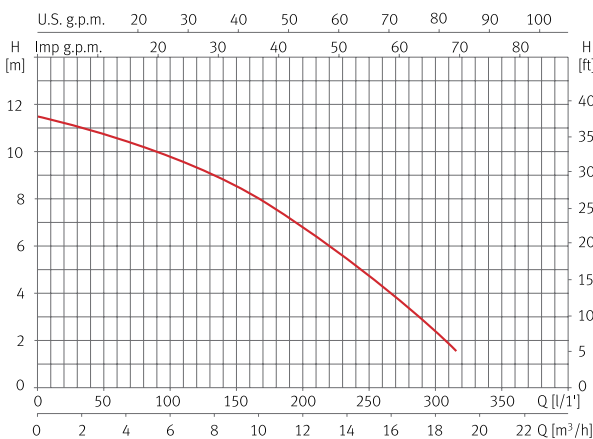

Dimension and weight

Model	A	B	C	Kg
Piscis 3	219	337	155	7

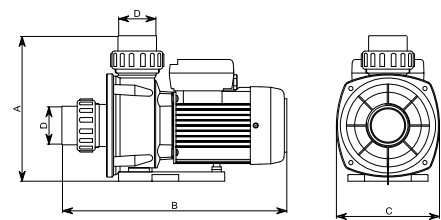







Evacuation

Say goodbye to
water, say hello
to efficiency

Portable submersible pump for waste water

Applications

Evacuation, transfer and emptying of waste water and emptying of swimming pools.

Materials

Pump in technopolymer.
Pump shaft in AISI 420.
Impeller in technopolymer.
Lip seal.
O-rings in NBR/EPDM.
Model H with internal parts in AISI 316.

Equipment

Float switch and 10m of cable with plug type F.
Internal capacitor.

Motor

Asynchronous 2 poles.
IPX8 protection.
Class F insulation.
Continuous operation.
Built-in thermal protection.

Range of use

Maximum water temperature 40 °C.
Maximum solids passage Ø 10mm.
Maximum submersion 2m.



Easy to use

Flow rate up to 260 l/min

Features table

Model	I [A]	P1 [kW]	P2		c [µF]	l/min	20	40	80	120	160	200	240	260	Code	
	1~230V	1~	[kW]	[HP]											m³/h	1,2
Vigila 200	1,8	0,38	0,25	0,33	8	mvc	5,6	5,3	4,5	2,8	-	-	-	-	105776	105779
Vigila 350	2,7	0,55	0,5	0,7	10		7,2	7	6,5	5,5	4	2	-	-	105781	105784
Vigila 500	3,7	0,85	0,6	0,8	10		10,4	10	9	8	6,8	5	3	1,8	105787	105790

Performance curve at 2900 rpm

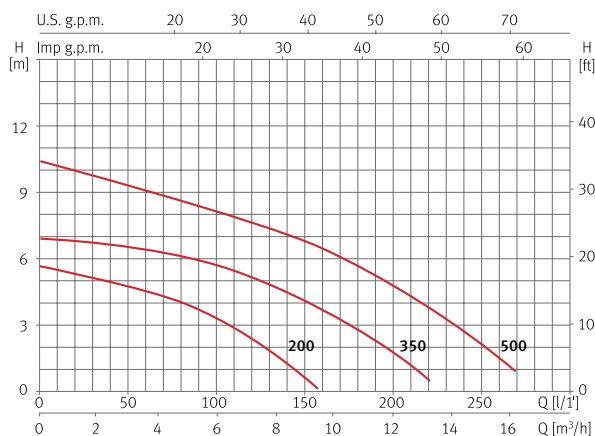

Dimension and weight

Model	A	B	C	D	E	F	G	H	Kg
Vigila 200	392	320	353	72	1 1/4"	214	291	201	4,5
Vigila 350	444	372	405	124	1 1/4"	214	291	201	6,7
Vigila 500	444	372	405	124	1 1/4"	214	291	201	7,1

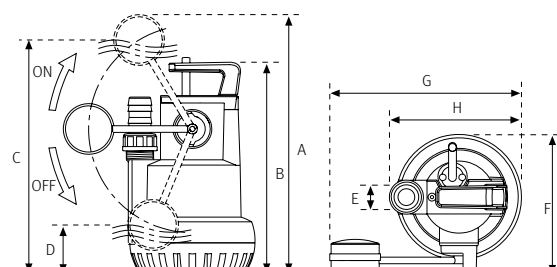

Portable submersible pump for waste water with solids in suspension, vortex system

Applications

Evacuation, transfer and emptying of waste water with solids in suspension.

Materials

Pump in technopolymer.
Pump shaft in AISI 420.
Impeller in technopolymer.
Lip seal.
O-rings in NBR/EPDM.
Model H with internal parts in AISI 316.

Motor

Asynchronous 2 poles.
IPX8 protection.
Class F insulation.
Continuous operation.
Built-in thermal protection.

Range of use

Maximum water temperature 40 °C.
Maximum solids passage Ø 25mm.
Maximum submersion 4m.

Equipment

Float switch and 10m of cable with plug type F.
Internal capacitor.



Solids throughput

Easy to use

Flow rate up to 240 l/min

Features table

Model	I [A]	P1 [kW]	P2		c [µF]	l/min	25	50	75	100	125	150	190	240	Code	
	1~230V	1~	[kW]	[HP]											m³/h	1~230V
Vigilex 300	2,5	0,6	0,5	0,7	10	mwc	5,7	5,2	4,6	3,8	3,2	2,3	1	-	105796	134347
Vigilex 600	3,3	0,8	0,6	0,8	10		7,5	7	6,3	5,6	5	4,3	3	1	105800	134348

Performance curve at 2900 rpm

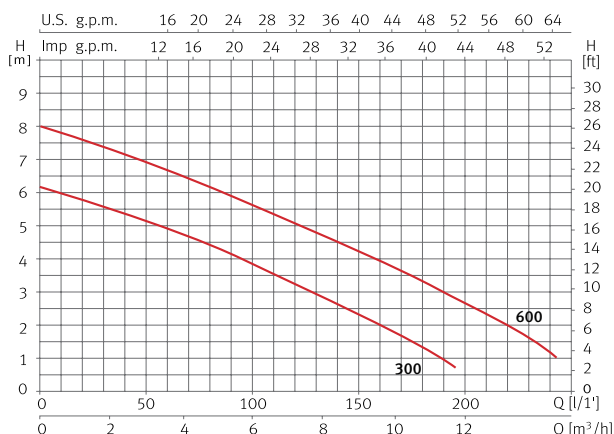

Dimension and weight

Model	A	B	C	D	E	F	Kg
Vigilex 300	380	362	1 1/4"	214	410	201	4,5
Vigilex 600	380	362	1 1/4"	214	410	201	6,7

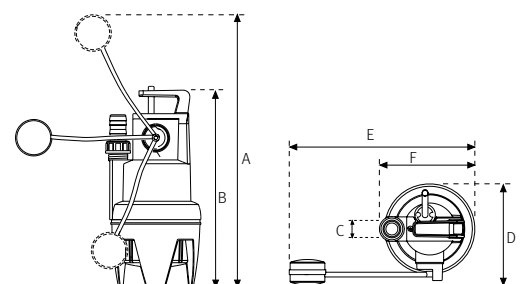

Submersible pump for waste water with solids in suspension, grinder system

Applications

Evacuation, transfer and emptying of waste water with solids in suspension.

Materials

Pump body in AISI 304.
 Pump shaft in AISI 420.
 Suction and discharge in cast iron.
 Impeller in technopolymer reinforced with steel.
 Grinder blade in stainless steel.
 Mechanical seal.
 O-rings in NBR/EPDM.

Equipment

Float switch and 10m of cable with plug type F.
 Internal capacitor.

Motor

Asynchronous 2 poles.
 IPX8 protection.
 Class F insulation.
 Continuous operation.
 Built-in thermal protection.

Range of use

Maximum water temperature 40 °C.
 Maximum submersion 7m.

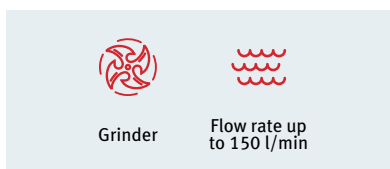

Features table

Model	I [A]	P1 [kW]	P2		c [μF]	l/min	15	30	50	65	80	100	115	135	Code
	1~230V	1~	[kW]	[HP]		m³/h	0,9	1,8	3,0	3,2	4,8	6,0	6,9	8,1	
Vigicor	5,4	1,2	0,9	1,2	16	mwc	21	19,1	17,1	15,5	14	11,4	9,4	6,5	97798

Performance curve at 2900 rpm

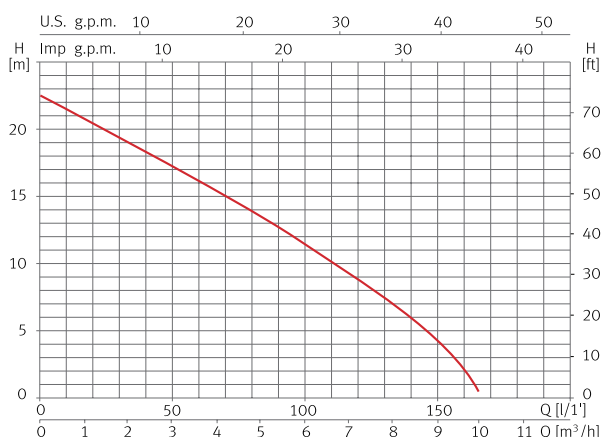

Dimension and weight

Model	A	B	C	D	E	F	G	Kg
Vigicor	396	471	148	151	57	191	1 1/4"	15,5

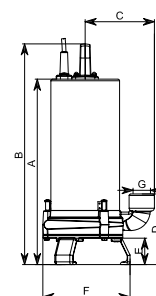

Submersible pump for waste water

Applications

Evacuation, transfer and emptying of waste water.

Materials

Pump body in AISI 304.
Pump shaft in AISI 420.
Impeller in technopolymer.
Suction and discharge in cast iron.
Double mechanical seal.
O-rings in NBR/EPDM.

Equipment

Float switch and 10m of cable with plug type F.
External capacitor with capacitor box included.

Motor

Asynchronous 2 poles.
IPX8 protection.
Continuous operation.
Class F insulation.
Built-in thermal protection.

Range of use

Maximum water temperature 40 °C.
Maximum solids passage Ø 7mm.
Maximum submersion 7m.



Box with external capacitor



Very compact



Very reliable



Flow rate up to 320 l/min

Features table

Model	I [A]	P1 [kW]	P2		c [µF]	l/min	25	50	100	150	200	250	300	320	Code
	1~230V	1~	[kW]	[HP]		m³/h	1,5	3,0	6,0	9,0	12	15	18	19,2	
Drain 100	3,1	0,8	0,75	1	12	mwc	9,2	9,1	8,7	7,8	6	4	2	1	96601

Performance curve at 2900 rpm

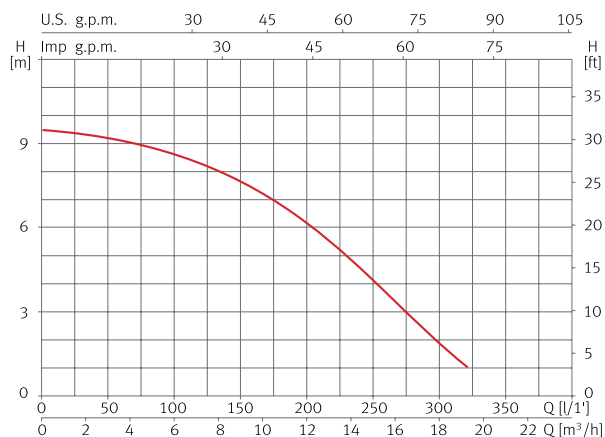

Dimension and weight

Model	A	B	C	Kg
Drain 100	122	392	1 1/4"	10,5

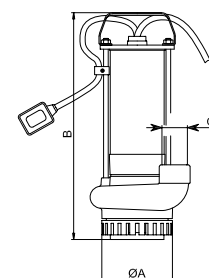

Drainex 100 **Evacuation | Drainage**



Submersible pump for waste water with solids in suspension, vortex system

Applications

Evacuation, transfer and emptying of waste water with solids in suspension.

Materials

Pump body in AISI 304.
Pump shaft in AISI 420.
Suction and discharge in cast iron.
Impeller in brass.
Double mechanical seal.
O-rings in NBR/EPDM.

Motor

Asynchronous 2 poles.
IPX8 protection.
Continuous operation.
Class F insulation.
Built-in thermal protection.

Range of use

Maximum water temperature 40 °C.
Maximum solids passage Ø 35mm.
Maximum submersion 7m.

Equipment

Float switch and 10m of cable with plug type F.
External capacitor with capacitor box included.



Brass impellers	Solids throughput	Box with external capacitor	Very compact	Very reliable	Flow rate up to 280 l/min

Features table

Model	I [A]	P1 [kW]	P2		c [µF]	l/min	25	50	100	125	150	200	250	280	Code
	1~230V	1~	[kW]	[HP]		m³/h	1,5	3,0	6,0	7,5	9,0	12	15	16,8	1~230V
Drainex 100	3,4	0,75	0,75	1	12	mwc	7	6,7	5,9	5,5	5	3,7	2	1	96625

Performance curve at 2900 rpm

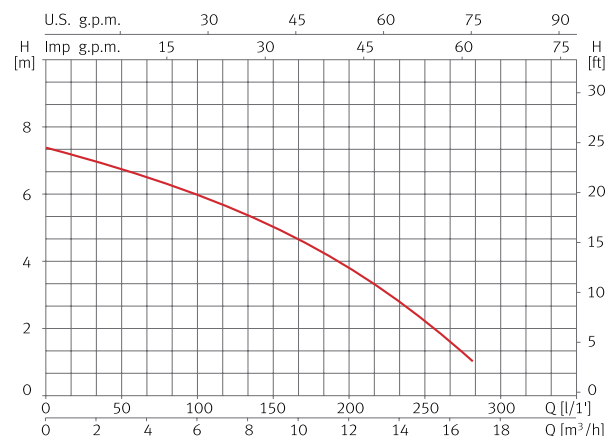

Dimension and weight

Model	A	B	C	Kg
Drainex 100	138	407	1 1/4"	11

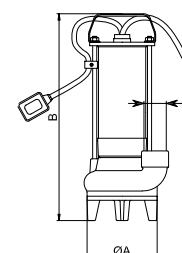

Drainex 200 **Evacuation | Drainage**



Submersible pump for waste water with solids in suspension, vortex system

Applications

Evacuation, transfer and emptying of waste water with solids in suspension.

Materials

Pump and impeller in cast iron.
Pump shaft in AISI 420.
Mechanical seal.
O-rings in NBR/EPDM.

Equipment

90° elbow included.
Model MA with float switch and 10m of cable with plug type F.
Model M without float switch and 10m of cable with plug type F.
Model T without float switch and 10m of cable without plug.
Internal capacitor.





Motor

Asynchronous 2 poles.
IPX8 protection.
Continuous operation.
Class F insulation.
Single phase motor with built-in thermal protection.

Range of use

Maximum water temperature 40 °C.
Maximum solids passage Ø 45mm.
Maximum submersion 7m.



			
Impellers in cast iron	Solids throughput	Robust	Flow rate up to 500 l/min

Features table

Model	I [A]		P1 [kW]		P2		c [µF]	l/min	50	100	200	300	400	500	Code		
	1~230V	3~400V	1~	3~	[kW]	[HP]									1~230V (Model M)	1~230V (Model MA)	3~400V (Model T)
Drainex 200	4	2,3	1,1	2,3	0,9	1,2	16	m³/h	3,0	6,0	12	18	24	30	96652	96654	96648
Drainex 201	4,5	2,6	1,4	1,4	0,9	1,2	16	m³/h	13,2	11,9	9,4	6,7	3,8	-	96664	96666	96662
Drainex 202	4,8	2,8	1,6	1,6	0,9	1,2	16	m³/h	15,1	13,8	11,3	8,5	5,6	2,5	96674	96676	96672

Performance curve at 2900 rpm

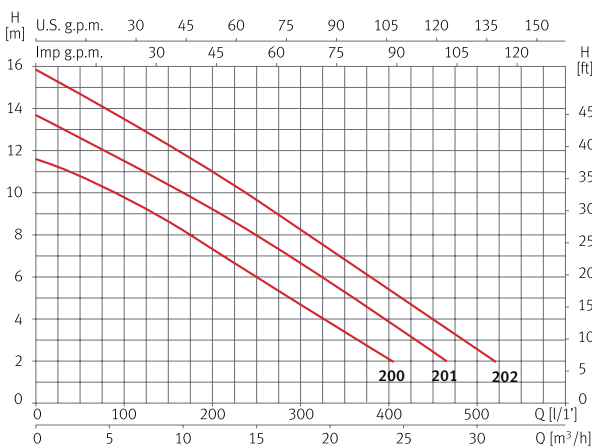

Dimension and weight

Model	A	B	C	D	E	F	G	H	Kg
Drainex 200	430	338	219	110	62	95	2"	2"	25
Drainex 201	430	338	219	110	62	95	2"	2"	25
Drainex 202	430	338	219	110	62	95	2"	2"	25

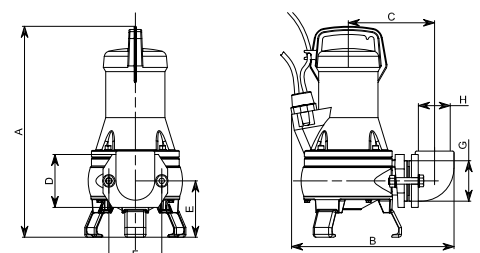

Dimension stationary version

A	B	C	D	E	F	G	H	I	J
388	353	119	168	60	112	2"	∅25	94	196

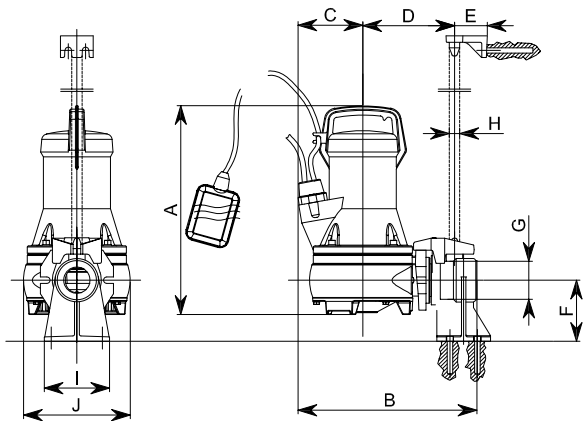

Stationary installation kit for Drainex 200 / 201 / 202



Support base for automatic anchoring



Clamping flange



Upper anchoring on guide tube

Kit	Code
DR1	100527

Submersible pump for waste water with solids in suspension, vortex system

Applications

Evacuation, transfer and emptying of waste water with solids in suspension.

Materials

Pump and impeller in cast iron.
Pump shaft in AISI 420.
Mechanical seal.
O-rings in NBR/EPDM.

Equipment

90° elbow included.
Model MA with float switch and 10m of cable with plug type F.
Model M without float switch and 10m of cable with plug type F.
Model T without float switch and 10m of cable without plug.
Internal capacitor.

Motor

Asynchronous 2 poles.
IPX8 protection.
Continuous operation.
Class F insulation.
Single phase motor with built-in thermal protection.

Range of use

Maximum water temperature 40 °C.
Maximum solids passage Ø 60mm.
Maximum submersion 7m.



Impellers in cast iron	Solids throughput	Robust	Flow rate up to 650 l/min

Features table

Model	I [A]		P1 [kW]		P2		c [µF]	l/min m³/h	50	100	200	400	500	650	Code		
	1~230V	3~400V	1~	3~	[kW]	[HP]			3,0	6,0	12	24	30	39	1~230V (Model M)	1~230V (Model MA)	3~400V (Model T)
Drainex 300	4,2	2,4	1,2	1,2	0,9	1,2	16	mwc	7,1	6,6	5,4	2,9	1,8	-	96684	96686	96682
Drainex 301	4,7	2,7	1,5	1,5	0,9	1,2	16		9,2	8,5	7	4,1	2,8	-	96694	96696	96692
Drainex 302	5,2	3	1,8	1,8	0,9	1,2	16		11	10,5	9	5,8	4,2	1,8	96704	96706	96702

Performance curve at 2900 rpm

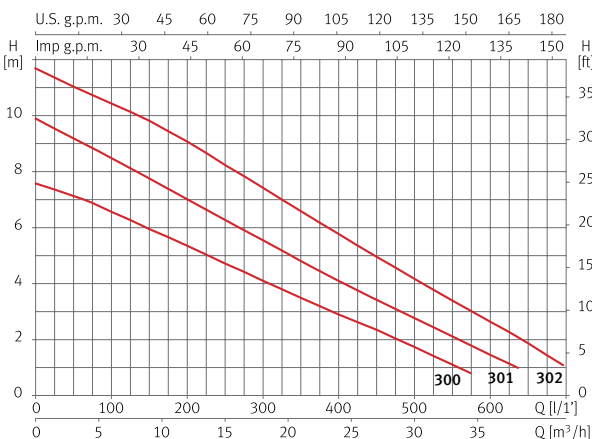

Dimension and weight

Model	A	B	C	D	E	F	G/H	Kg
Drainex 300	455	373	213	62	101	110	2 1/2"	28
Drainex 301	455	373	213	62	101	110	2 1/2"	28
Drainex 302	455	373	213	62	101	110	2 1/2"	28

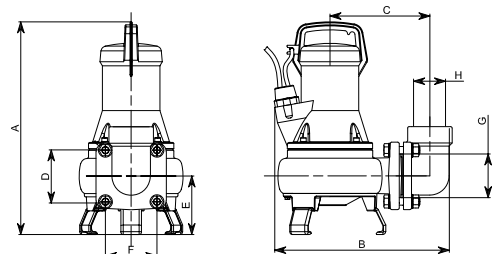

Dimension stationary version

A	B	C	D	E	F	G	H	I	J
405	441	108	246	92	132	2 ^{1/2} "	Ø42	40	222

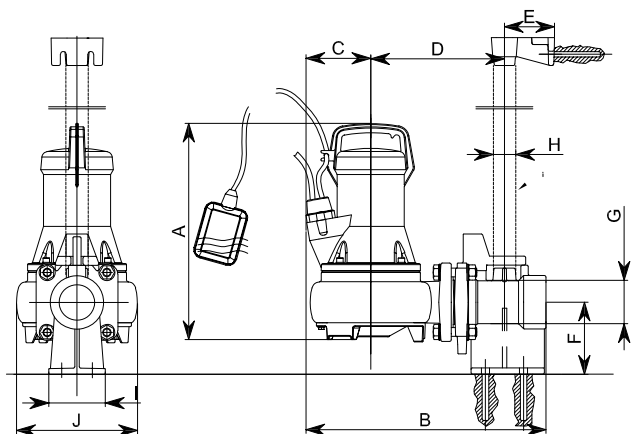

Stationary installation kit for Drainex 300 / 301 / 302



Support base for automatic anchoring



Clamping flange



Upper anchoring on guide tube

Kit	Code
DR2	100528

Drainex 400 **Evacuation | Drainage**



Submersible pump for waste water with solids in suspension, vortex system

Applications

Evacuation, transfer and emptying of waste water with solids in suspension.

Materials

Pump and impeller in cast iron.
Pump shaft in AISI 420.
Mechanical seal.
O-rings in NBR/EPDM.

Equipment

10m of cable without plug.

Motor

Asynchronous 2 poles.
IPX8 protection.
Continuous operation.
Class F insulation.

Range of use

Maximum water temperature 40 °C.
Maximum solids passage Ø 45mm.
Maximum submersion 7m.



Impellers in cast iron



Solids throughput



Robust



Flow rate up to 800 l/min

Features table

Model	I [A]	P1 [kW]	P2		l/min	100	200	400	500	600	700	800	Code
	3~400V	3~	[kW]	[HP]									
Drainex 400	4,1	2	2,6	3,5	mwc	14,6	12,7	8,3	5,9	2,8	-	-	137506
Drainex 401	4,7	2,5	2,6	3,5		17,3	15,5	11,6	9,3	5,2	3	-	137503
Drainex 402	5,5	3,2	2,6	3,5		20,7	18,6	13,7	12	9,3	5	2	129725

Performance curve at 2900 rpm

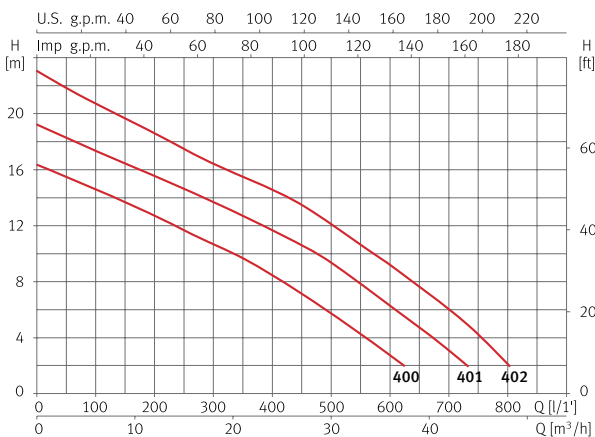

Dimension and weight

Model	A	B	C	D	E	F	G	H/J	I	K	Kg
Drainex 400	537	408	238	124	110	134	188	110	135	50	45
Drainex 401	537	408	238	124	110	134	188	110	135	50	45
Drainex 402	537	408	238	124	110	134	188	110	135	50	45

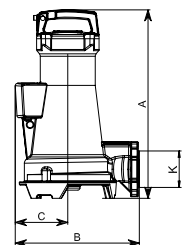
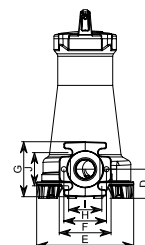

Dimension stationary version

A	B	C	D	E	F	G	H	I	J/K
562	589	136	257	62	244	231	165	102	251

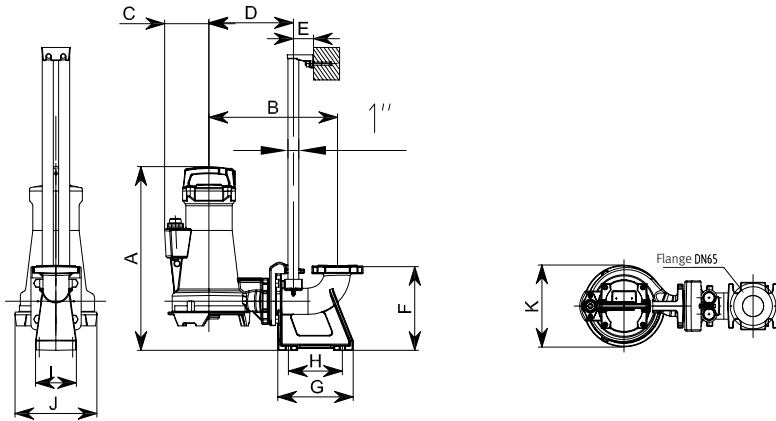

Stationary installation kit for Drainex 400 / 401 / 402

DN65 (flange 65)

DIN 2501 PN16

ANSI 150 2"



Support base with elbow for automatic anchoring



Clamping flange



Upper anchoring on double guide tube

Kit	Code
DR3.2	207381

Portable installation kit for Drainex 400 / 401 / 402



90° elbow at 2"



Stainless steel feet

Kit	Code
DR6	132139

Drainex 500 **Evacuation | Drainage**



Submersible pump for waste water with solids in suspension, vortex system

Applications

Evacuation, transfer and emptying of waste water with solids in suspension.

Materials

Pump and impeller in cast iron.
Pump shaft in AISI 420.
Mechanical seal.
O-rings in NBR/EPDM.

Equipment

10m of cable without plug.

Motor

Asynchronous 2 poles.
IPX8 protection.
Continuous operation.
Class F insulation.

Range of use

Maximum water temperature 40 °C.
Maximum solids passage Ø 45mm.
Maximum submersion 7m.



Impellers in cast iron	Solids throughput	Robust	Flow rate up to 750 l/min

Features table

Model	I [A]	P1 [kW]	P2		l/min	100	300	400	500	600	750	Code
	3~400V	3~	[kW]	[HP]								
Drainex 500	6,6	3,8	3,7	5	mwc	23,2	19,7	17,6	15,6	13	8,5	137507
Drainex 501	7,9	4,7	3,7	5		27,4	23,5	21,2	19,1	16,8	12	137504
Drainex 502	8,2	4,8	3,7	5		30,1	26,8	24,5	22,2	20	15,4	129726

Performance curve at 2900 rpm

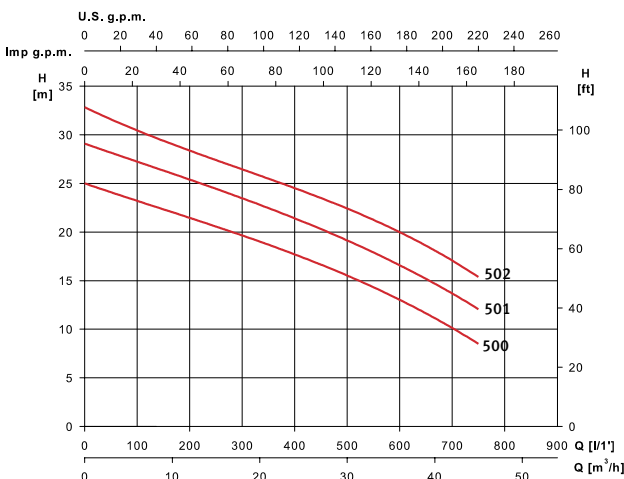

Dimension and weight

Model	A	B	C	D	E	F	G	H	I/J	K	Kg
Drainex 500	575	412	139	186	256	134	140	110	88	50	55
Drainex 501	575	412	139	186	256	134	140	110	88	50	55
Drainex 502	575	412	139	186	256	134	140	110	88	50	55

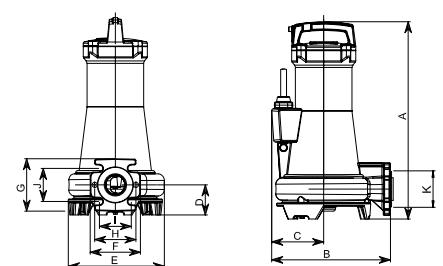

Dimension stationary version

A	B	C	D	E	F	G	H	I	J/K
596	389	139	254	62	244	231	165	102	125

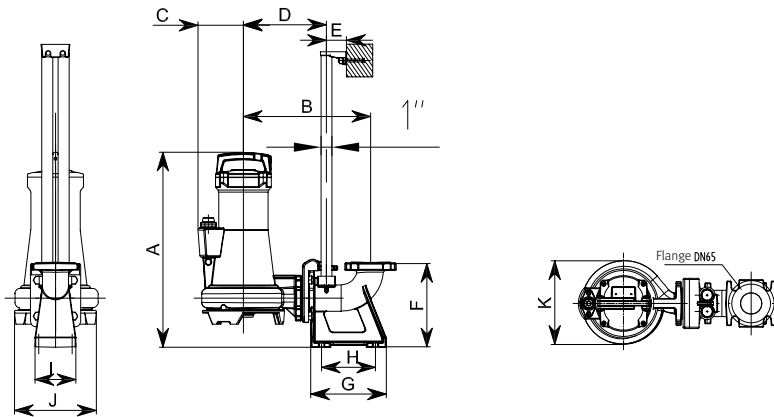

Stationary installation kit for Drainex 500 / 501 / 502

DN65 (flange 65)

DIN 2501 PN16

ANSI 150 2"



Support base with elbow for automatic anchoring



Clamping flange



Upper anchoring on double guide tube

Kit	Code
DR3.2	207381

Portable installation kit for Drainex 500 / 501 / 502



90° elbow at 2°



Stainless steel feet

Kit	Code
DR6	132139

Submersible pump for waste water with solids in suspension, vortex system

Applications

Evacuation, transfer and emptying of waste water with solids in suspension.

Materials

Pump and impeller in cast iron.
Pump shaft in AISI 420.
Mechanical seal.
O-rings in NBR/EPDM.

Equipment

10m of cable without plug.

Motor

Asynchronous 2 poles.
IPX8 protection.
Continuous operation.
Class F insulation.

Range of use

Maximum water temperature 40 °C.
Maximum solids passage Ø 65mm.
Maximum submersion 7m.



Impellers in cast iron	Grinder	Robust	Flow rate up to 1.200 l/min

Features table

Model	I [A]	P1 [kW]	P2		l/min	200	400	600	800	1.000	1.200	Code
	3~400V	3~	[kW]	[HP]								
Drainex 600	5,5	3	3,7	5	mwc	14,8	13,3	10,4	6,3	3,4	-	137508
Drainex 601	6,4	3,7	3,7	5		18	16,3	14	9,8	6	3,1	137505

Performance curve at 2900 rpm

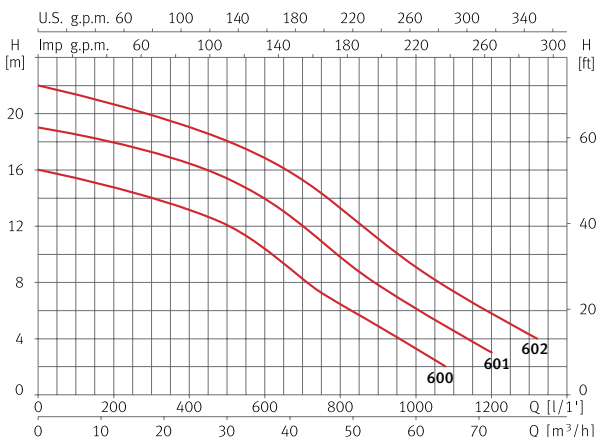

Dimension and weight

Model	A	B	C	D	E	F	G	H	I/J	K	Kg
Drainex 600	616	458	272	136	254	110	144	150	110	65	60
Drainex 601	616	458	272	136	254	110	144	150	110	65	60

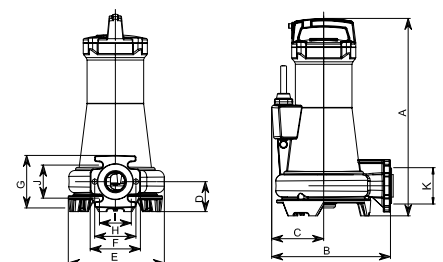

Dimension stationary version

A	B	C	D	E	F	G	H	I	J/K
630	419	319	257	62	260	231	165	102	125

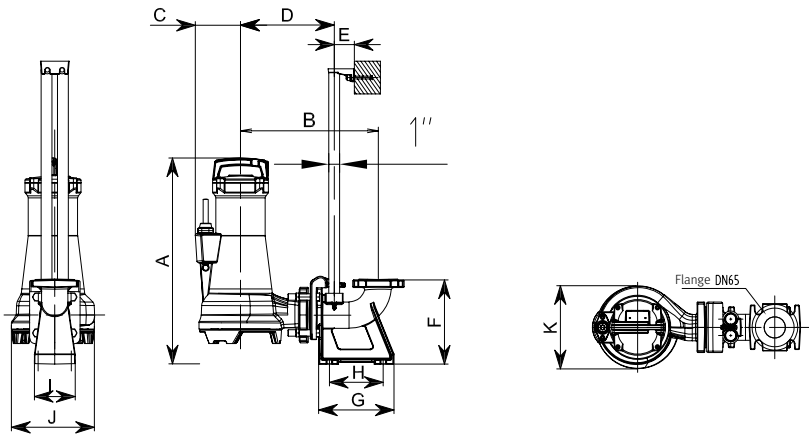

Stationary installation kit for Drainex 600 / 601 / 602

DN65 (flange 65)



Support base with elbow for automatic anchoring

DIN 2501 PN16



Clamping flange

ANSI 150 2 1/2"



Upper anchoring on double guide tube

Kit	Code
DR4.2	207379

Portable installation kit for Drainex 600 / 601 / 602



90° elbow at 2 1/2"



Stainless steel feet

Kit	Code
DR7	132140

Submersible pump for waste water with solids in suspension, grinder system

Applications

Evacuation, transfer and emptying of waste water with solids in suspension.

Materials

Pump and impeller in cast iron.
Grinder blade in steel.
Pump shaft in AISI 420.
Mechanical seal.
O-rings in NBR/EPDM.

Equipment

90° elbow included.
Model MA with float switch and 10m of cable without plug.
Model M/T without float switch and 10m of cable without plug.
External capacitor with capacitor box included.

Motor

Asynchronous 2 poles.
IPX8 protection.
Continuous operation.
Class F insulation.
Single phase motor with built-in thermal protection.

Range of use

Maximum water temperature 40 °C.
Maximum submersion 7m.



Impellers in cast iron	Grinder	Robust	Flow rate up to 250 l/min

Features table

Model	I [A]		P1 [kW]		P2		c [μF]	l/min m³/h	25	50	100	150	200	250	Code		
	1~230V	3~400V	1~	3~	[kW]	[HP]									1~230V (Model M)	1~230V (Model MA)	3~400V (Model T)
Draincor	6,4	2,6	1,4	1,4	0,9	1,2	16/50	mwc	17	15	13	10	7	5	213497	213498	96617

Performance curve at 2900 rpm

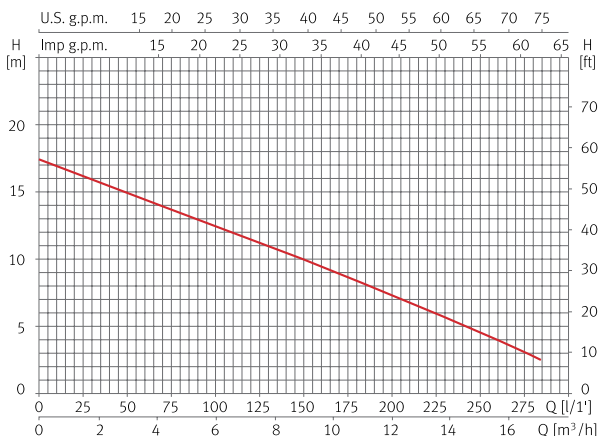

Dimension and weight

Model	A	B	C	D	E	F	G	Kg
Draincor	437	338	219	110	95	110	2"	25

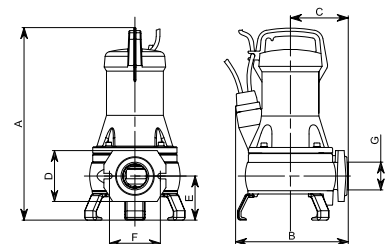

Dimension stationary version

A	B	C	D	E	F	G	H	I	J
388	353	110	168	60	112	2"	Ø25	94	120

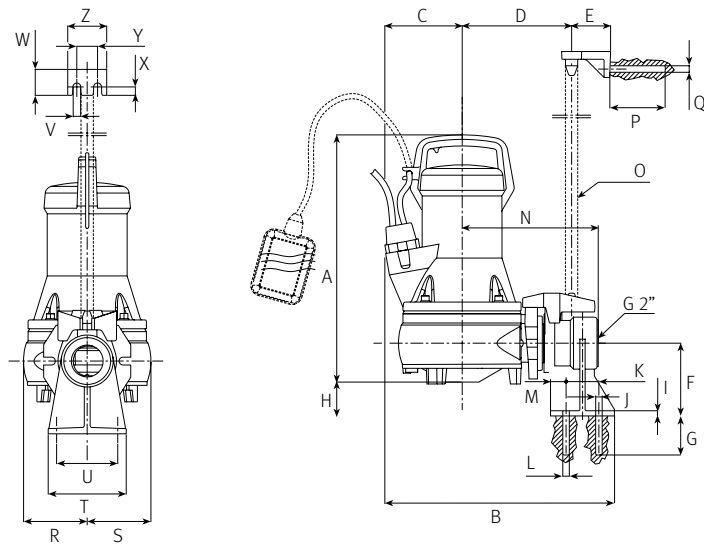

Stationary installation kit for Draincor



Support base for automatic anchoring



Clamping flange



Upper anchoring on guide tube

Kit	Code
DR1	100527

Set for waste water with solids in suspension, vortex system

Applications

Collection, storage and evacuation of waste water with solids in suspension. For domestic, industrial, agricultural and gardening purposes.

Materials

Drainex 201:

Pump and impeller in cast iron.
Pump shaft in AISI 420.
Mechanical seal.
O-rings in NBR.
Tank: Polyethylene.

Equipment

Built-in check valve.
10m of cable with plug type F.
Internal capacitor.
Control panel included.

Motor

Asynchronous 2 poles.
IPX8 protection.
Class F insulation.
Continuous operation.
Single phase motor with built-in thermal protection.

Range of use

Maximum water temperature 40 °C.
Maximum solids passage Ø 45mm.



Drainbox 300 1400



Drainbox 600 1400



Complete set



Solids throughput



Flow rate up to 800 l/min

Features table

Model	I [A]		P1 [kW]		P2		Tank capacity [l]	Tank suction connection	Ø Pump discharge	Tank discharge connection	Maximum flow [l/min]	Code	
	1~230V	3~400V	1~	3~	[kW]	[HP]						1~230V	3~400V
Drainbox 300 1400 (Drainex 201)	6,6	2,6	1,4	1,4	1,1	1,5	300	DN 100	2"	Adjustable position	450	148154	148155
Drainbox 600 1400 (Drainex 201)	2 x 6,6	2 x 2,6	2 x 1,4	2 x 1,4	2 x 1,1	2 x 1,5	600	2 x DN 100	2"		900	148156	148158

Performance curve at 2900 rpm

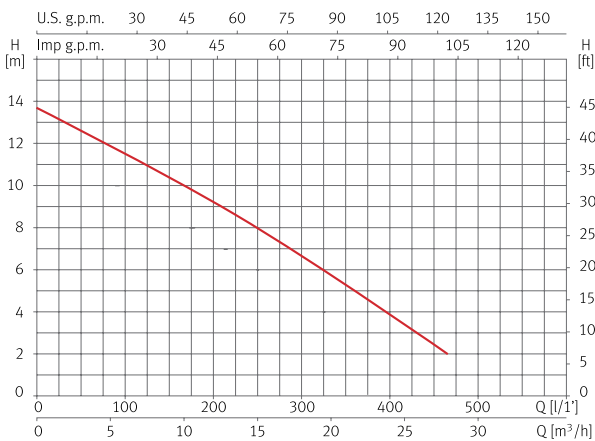

Dimension and weight

Model	A	B	C	Kg
Drainbox 300 1400	770	760	615	55
Drainbox 600 1400	1230	760	615	110

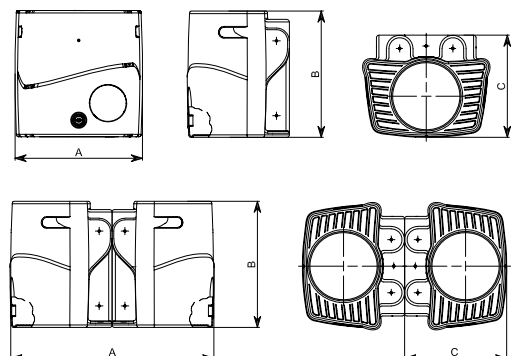

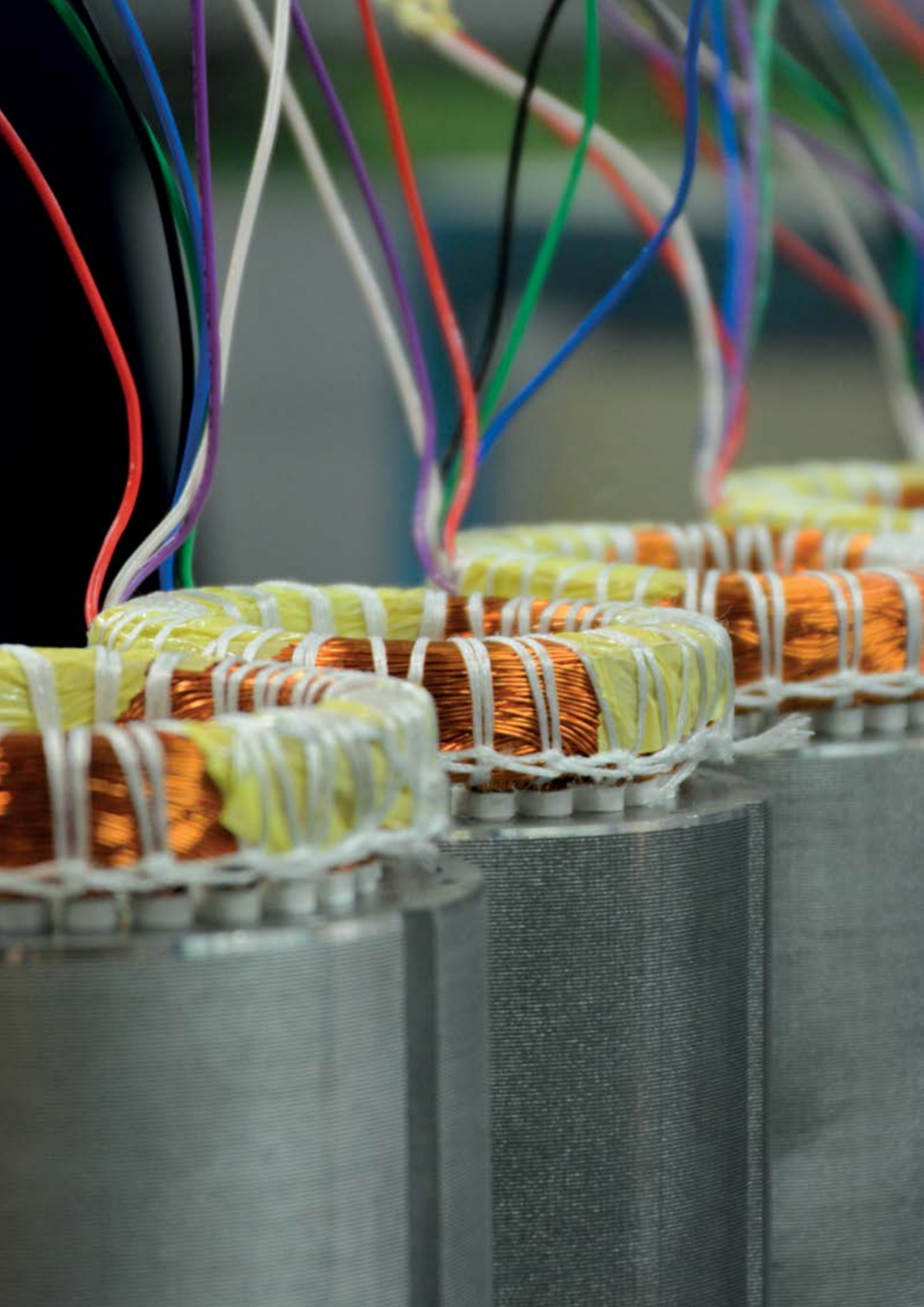



Accessories





Kit to prevent the water hammer

Model	Connection	Code
Kit Press	1/4" thread	169961



Float switch for open wells and tanks

Model	Length [m]	Code
IN15	3	3533



Float switch for waste water

Model	Length [m]	Code
F10	6	103219



Automatic control and protection panel for submersible pumps

Model	Motor Range of use [HP]	Amp. up to [A]	Code
PROTEC 1~230V	0,5 - 3	20	134310
PROTEC 3~400V	0,5 - 4	10	134308
PROTEC 3~400V	5,5 - 7,5	20	134309

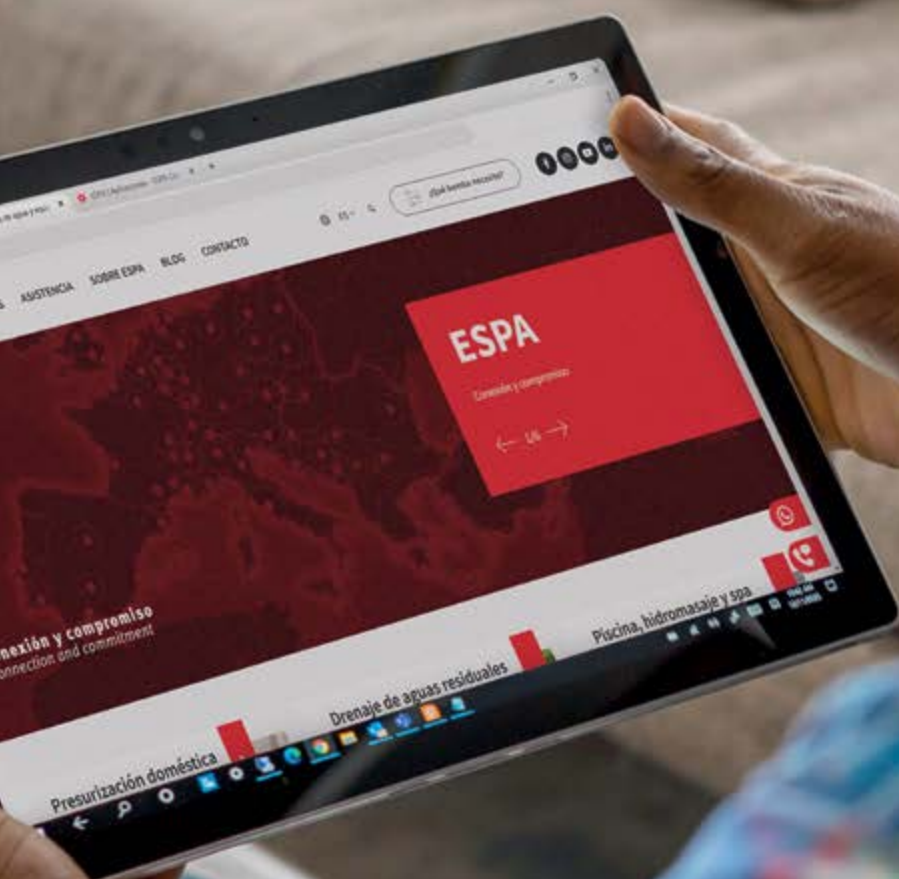

Information

Quality at ESPA is much more than an objective or a market requirement; it is something that is part of our way of being and corporate culture.

ESPA guarantees the complete product cycle: design, development, production, business, after-sales service and environmental management, certified by **ISO 9001:2015** (quality management) and **ISO 14001:2015** (environmental management) standards.

ESPA fully guarantees its products in accordance with the Legislative Decree 1/2007 of November 16th, thanks to a quality assurance system and exhaustive in-process and final control procedures.

Millions of ESPA pumps are working at full capacity all over the world. Thousands of installations show the confidence that professionals and users have placed in ESPA.

All the products in this catalogue comply with the following standards:

- › **Directive 2006/42/CE** about machine security. Standard EN 809 and EN 60204-1.
- › **Directive 2014/35/UE** about low voltage. Standards EN 60335-1 and EN 60335-2-41.
- › **Directive 2014/30/UE** about electromagnetic compatibility. Standards EN 61000-6-1 and EN 61000-6-3.
- › **Directive 2000/14/CE** about sound emissions. EN-ISO 3744
- › **Directive 2009/125/CE** about eco-design of energy-related products. Regulation (EU) 2019/1781 for electric motors and variable speed drives. Standard EN 60034-30.
- › **Directive 2012/19/UE** about waste electrical and electronic equipment (WEEE). Standard EN 50419:2006 on the marking of electrical and electronic equipment.
- › **Directive 2011/65/UE** about restrictions on the use of hazardous substances. Standard UNE-EN IEC 63000:2022.
- › **Directive 94/62/CE** about packaging and packaging waste.
- › **Directive 2006/66/CE** about batteries and accumulators and their waste.
- › **Directive 2014/53/UE** about radio equipment:
 - › Standard EN 300328 and EN 301489-17.
 - › Standard EN 62479 and EN 60950-1.

Note: We have some products **certified with SHW for drinking water**, an essential regulation in France for materials in contact with drinking water, which is being progressively implemented throughout the European Union.

ESPA voltages

Voltage tolerances:

Nominal 230V [+/- 10%].

Nominal 400V [+/- 10%].

Non-binding pictures, the technical specifications and/or the equipment might change depending on the model. ESPA has the right to change the content of the present catalogue without any further notice, always with the intention to improve the information that is given to our clients.

The data containing this catalogue is valid, except for any spelling or printing mistakes, until a new version of the catalogue is released.

- › Check out the brand protection measures at **www.espa.com**.



We design



We produce



We distribute



Trust ESPA, your ally in each installation

We understand the needs of installers like you, as we have spent decades designing solutions designed to make your work easier and offer maximum efficiency. From state-of-the-art hydraulic pumps to complete pressurisation systems, each product is manufactured to ensure durability, performance and ease of installation. Furthermore, with our specialised Technical Service, you will always have the support you need. Whether it's a consultation, maintenance or after-sales support, we are at your side to make sure every project is a success.

With ESPA you not only work with cutting-edge technology, but you also work with a team committed to making your life easier. **Find out about all our solutions at:**

 [ESPAGlobal](#)

 [espagroup](#)

 [espa-group](#)

 [ESPAgroup](#)

 +34 972 588 000

 [www.espa.com](#)



FSC
www.fsc.org

MIXT

Paper | Donant
suport a la
silvicultura
responsable

FSC® C015546



ESPA GROUP

hello@espa.com

www.espa.com

